



UNIVERSITAT DE
BARCELONA

Facultat de Farmàcia
i Ciències de l'Alimentació

Final Degree Project

FACULTAT DE FARMÀCIA I CIÈNCIES DE L'ALIMENTACIÓ

UNIVERSITAT DE BARCELONA

CD19-TARGETED CAR T CELLS THERAPY

IVAN VENTOSA NIVET

MAIN FIELD: Biochemistry and Molecular Biology

SECONDARY FIELDS: Cell Biology, Immunology, Physiology and
Physiopathology

Barcelona, June 2020



This work is licenced under a [Creative Commons license](https://creativecommons.org/licenses/by-nc-nd/4.0/)

ACKNOWLEDGEMENTS

I would like to thank Almudena Soriano Ruiz, laboratory technician in the Banc de Sang i Teixits, for her kindness and generosity in having several conversations with me that helped me to elaborate important parts of this project.

INDEX

ABSTRACT - RESUM	I
ABBREVIATIONS	III
INTEGRATION OF DIFFERENT SCOPES	V
INTRODUCTION	1
Immune system	1
External defensive barriers.....	1
Innate response.....	1
Adaptative response.....	2
T lymphocytes	2
Structure.....	2
Functions.....	2
Activation.....	3
Amplification of the signal: different pathways.....	4
B lymphocytes	5
Structure.....	5
Functions.....	6
Basis of B-cell activation.....	6
Immunotherapy and cancer	7
OBJECTIVES	9
MATERIAL AND METHODS	9
RESULTS	10
The history of CAR-T cells	10
Cancer cell therapy	11
Adoptive Cell Therapy.....	11
CAR T cells.....	12
CD19 CAR Therapy: Kymriah® and Yescarta®	13
General information.....	13
CD28 and 4-1BB: different costimulatory domains.....	14
Therapeutic context.....	15
B-cell acute lymphoblastic leukaemia (ALL).....	15
Diffuse large B cell lymphoma (DLBCL).....	16
Primary mediastinal large B cell lymphoma (PMLBCL).....	16

Manufacturing of CAR-T cells	16
Leukapheresis, preservation and transport	17
Manufacturing process: genetic engineering.	17
Administration into patients: pharmaco-clinical protocol.....	19
Use of tisagenlecleucel and axicabtagene ciloleucel for DLBCL	19
Use of tisagenlecleucel for B-ALL.....	19
Prior treatment and post-administration monitoring	20
Common toxicities of Kymriah® and Yescarta®	21
Cytokine release syndrome	21
Neurotoxicity	22
National approach: situation in Catalonia.....	22
Current situation	22
Banc de Sang i Teixits: cell-processing laboratory	23
<i>Step into the future</i>	25
From autologous to allogeneic	25
Solid tumours	25
<i>DISCUSSION</i>	26
<i>CONCLUSIONS</i>.....	27
<i>BIBLIOGRAPHY</i>.....	28

ABSTRACT - RESUM

CD19-TARGETED CAR T CELLS THERAPY

Over the years, the scientific community has been studying and exploring different strategies to treat cancer using gene therapy techniques that have culminated in the development of an immunotherapy called Chimeric Antigen Receptor (CAR) T cells therapy.

Recently, two different types of CAR T cell therapies have been approved to treat B cell malignancies by the FDA and the AEMPS: tisagenlecleucel (Kymriah®) and axicabtagene ciloleucel (Yescarta®), becoming an important paradigm shift due to their special characteristics. These medicines are autologous biological medicines where immune cells, concretely T lymphocytes, are collected from the blood of the patient, processed and sent to manufacturing facilities. There, gene-editing modification is performed through viral vectors in order to express certain chimeric antigen receptors in the cell membrane of the T lymphocytes. Here comes the key to the success of these revolutionary therapies: these artificial receptors are able to get linked and recognize specific antigen, CD19, that is expressed in the entire B-cell lineage. Once they recognize it, T-cell expansion, cytotoxic activity, releasing of cytokines and pro-inflammatory substances happen and, therefore, anti-tumour effects are achieved.

In addition, an analysis of the situation in our country related to these therapies will be performed: the Banc de Sang i Teixits (BST) plays an important role in the manufacturing process since they collect leukapheresis material, process it and cryopreserve it before it is shipped to manufacturing facilities and the other way around.

Finally, current challenges of these therapies such as side effects and logistic aspects will be discussed. Furthermore, the possible future perspectives of these immunotherapies will be exposed.

TERÀPIA AMB CÈL·LULES CAR-T CD19

Durant els darrers anys, la comunitat científica ha investigat i explorat diferents estratègies per poder tractar el càncer mitjançant tècniques de teràpia gènica que han culminat en el desenvolupament d'una nova immunoteràpia anomenada teràpia de cèl·lules CAR T (T cell Chimeric Antigen Receptor).

Recentment, la FDA i l'AEMPS han aprovat dues noves teràpies CAR T per al tractament de certes leucèmies i limfomes que afecten als limfòcits B: tisagenlecleucel (Kymriah®) i axicabtagen ciloleucel (Yescarta®), convertint-se en un complet canvi de paradigma degut a les seves característiques. Aquests nous fàrmacs són medicaments biològics d'ús autòleg procedents de l'extracció de limfòcits T de la sang del pacient, que es processen i s'envien als laboratoris elaboradors. En aquestes instal·lacions, els limfòcits T pateixen modificacions genètiques gràcies a vectors virals que conduiran a l'expressió d'un receptor específic a la membrana d'aquestes cèl·lules quimèriques. Aquest receptor d'antigen quimèric és el principal motiu de l'èxit d'aquestes immunoteràpies, ja que és capaç de reconèixer un antigen específic, el CD19, que es troba expressat en

tot el llinatge dels limfòcits B. Un cop l'antigen és reconegut, aquests limfòcits T modificats són activats i diversos mecanismes entren en acció, com per exemple el creixement de la població de limfòcits T, l'alliberació de citocines i substàncies pro-inflamatòries, entre d'altres, amb l'objectiu final d'obtenir una robusta activitat citotòxica, i en conseqüència, efectes anti-tumorals.

A més a més, en aquest treball es durà a terme un anàlisi de la situació i implementació d'aquestes teràpies en el nostre país, on el Banc de Sang i Teixits (BST) té un paper important. El BST participa en el procés d'elaboració dels fàrmacs ja que s'encarrega de la recol·lecció del material d'afèresi, del seu processament cel·lular i criopreservació abans de ser enviat a les instal·lacions de fabricació; així com en el camí invers.

Finalment, seran tractats diversos conceptes com per exemple els reptes actuals sobre efectes adversos i logística, i també quines perspectives de futur té aquest tipus de teràpia i com podria evolucionar.

ABBREVIATIONS

ACD-A: Anticoagulant Citrate Dextrose solution A.

ACT: Adoptive Cell Therapy.

AEMPS: Agencia Española de Medicamentos y Productos Sanitarios.

ALL: Acute Lymphoblastic Leukaemia.

APC: Antigen-Presenting Cell.

B7: actually B7.1 and B7.2 (also known as CD80/CD86).

BCR: B-Cell Receptor.

BST: Banc de Sang i Teixits.

CAR: Chimeric Antigen Receptor.

CD: Cluster of Differentiation.

C_H: constant region of Ig heavy chain.

C_L: constant region of Ig light chain.

CNS: Central Nervous System.

CR2: Complement Receptor type 2.

CRES: CAR-T cell Related Encephalopathy Syndrome.

CRS: Cytokine Release Syndrome.

CTL: Cytotoxic T Lymphocyte.

CTL019: tisagenlecleucel.

DIN: Donation Identification Number.

DLBCL: Diffuse Large B Cell Lymphoma.

DMSO: Dimethyl Sulfoxide.

FDA: Food and Drug Administration.

FIN: Facility Identification Number.

GADS: GRB2-related adaptor protein.

GMP: Good Manufacturing Practices.

GRB2: Growth Factor Receptor-Binding Protein 2.

GVHD: Graft-Versus-Host Disease.

HIV: Human Immunodeficiency Virus.

HLA: Human Leucocyte Antigen.

HSA: Human Serum Albumin.

ICAM-1: Intercellular Adhesion Molecule-1.

IFN γ : γ -interferon.

IgA: Immunoglobulin A (also D, E, G and M).

IL-2: Interleukin-2 (also 4, 5, 6, 13, 15 and 17).

ISBT: International Society of Blood Transfusion.

ITAM: Immunoreceptor Tyrosine-based Activation Motif.

JAK: Janus Kinases.

KTE-C19: axicabtagene ciloleucel.

LAT: Linker for Activation of T-cells.

LEU13: also known as CD225.

LFA-1: Lymphocyte Function-Associated Antigen-1 (also Antigen-3).

MAPK: Mitogen-Activated Protein Kinase.

MHC: Major Histocompatibility Complex.

MSCBS: Ministerio de Sanidad, Consumo y Bienestar Social.

MZ: Marginal-Zone.

NFAT: Nuclear Factor of Activated T-cells.

PAMP: Pathogen-Associated Molecular Pattern.

PBMC: Peripheral Blood Mononuclear Cell.

PDK1: Pyruvate Dehydrogenase Kinase 1.

PKC: Protein Kinase C.

PLC γ 1: Phospholipase C γ 1.

PMLBCL: Primary Mediastinal Large B-Cell Lymphoma.

PRR: Pattern Recognition Receptor.

PSMA: Prostate-Specific Membrane Antigen.

PTK: Protein Tyrosine Kinase.

r/r: relapsed/refractory.

scFv or Fv: single chain V_H-V_L antigen binding fragment.

SEC: Single European Code.

SLP-76: SH2-domain containing Leukocyte Protein of 76kDa.

SNS: Sistema Nacional de Salud.

STAT3: Signal Transducer and Activator of Transcription 3 (also STAT5).

TAPA-1: also known as CD81.

T_{CM}: Central Memory T-cell.

TCR: T-Cell Receptor.

T_{EM}: Effector Memory T-cell.

TIL: Tumour-Infiltrating Lymphocytes.

TNC: Total Nucleated Cell.

TRUCK: T cell Redirected for Universal Cytokine-mediated Killing.

VCAM-1: Vascular Cell Adhesion Molecule.

V_H: variable region of Ig heavy chain.

V_L: variable region of Ig light chain.

VLA-4: Very Late Antigen-4.

ZAP-70: Zeta Chain-Associated Protein of 70kDa

INTEGRATION OF DIFFERENT SCOPES

CAR T cell therapy is a complex concept that requires possessing robust notions about different scientific fields in order to understand it completely. The main field of this final degree project is **Biochemistry and Molecular Biology** since this field establishes the fundamental bases on which this project is based on.

However, in order to fully understand CAR T cell concept, the reader might need some knowledge of other fields of science so as to embrace the whole context where CAR T cell therapies take place. As a consequence, there are secondary fields that will be involved in this project, for instance **Immunology**, which is a science field that studies the immune system, its structure, function and importance, helping to contextualises several diseases related to immune system such as B cell malignancies.

Regarding to these B cell malignancies, axicabtagene ciloleucel and tisagenlecleucel are immunotherapies indicated for the treatment of certain leukaemias and lymphomas, whose physiopathological mechanism is very attached to how these medicines act in our organism; that is why certain knowledge in **Physiology and Physiopathology** it is required.

Finally, another scientific area of knowledge that can provide basic information to integrate, assimilate and comprehend the aspects discussed in this project is **Cell Biology**, which consists on the study of the cell, its composition, functions and main metabolic mechanisms and processes.

INTRODUCTION

Immune system

The immune system is one of the most incredible and complex mechanisms to respond against infections and cancer. It is formed by different types of cells, tissues and molecules that work and collaborate to act coordinately in the immune response. Immune system must be capable of recognising, identifying and developing the correct defence mechanism in order to destroy foreign entities and prevent organ damage.

The immune response is diverse and there are three different levels of immunity: external defensive barriers, innate response and adaptive immune response [1].

External defensive barriers

When an infectious agent penetrates inside the human body and induces immune response is because the external defensive barriers have failed and the agent has been capable of making his way through and get into. This first level of defence is formed by physical, chemical and biological barriers [2]. **Physical barriers** are composed of skin surface and mucus secretions that cover and protect the epidermal layers of inner tracts of organs and systems that have access to the external environment, such as respiratory, digestive and reproductive systems. The function and importance of this physical defence are supported by **chemical barriers**, for example the buccal cavity contains salivary proteins like lysozyme that has antimicrobial and bactericidal functions [3]; another important example is the maintenance of specific pH levels in some crucial areas of the digestive system to avoid the entrance of pathogenic microorganisms. The third barrier is called **biological barrier** and it consists of the bacterial population that humans host inside certain organs like the gut (gut microbiota) and the presence of this huge number of microorganisms make the colonization of pathogenic bacteria difficult which, in turn, could lead to an infection [4].

Innate response

The second level of immune response is called innate response: it is based on recognizing (through Pattern Recognition Receptors, PRRs) different molecular patterns and components (Pathogen Associated Molecular Patterns, PAMPs) that are associated to groups of pathogens because these structures have been conserved during millions of years of evolution. This innate response starts in the first place when pathogenic agents enter inside of the organism and this response remains activated during the next few days.

The main components that take part in this response are **macrophages, neutrophils** and different types of proteins with bactericidal properties such as **lysozyme** and **complement**. Even though innate response is usually highly effective, some infectious agents are able to resist and avoid this first attack. If innate response is not enough to neutralize the agent, this response tries to contain and remain under control the hazard while the immune system is developing the next mechanism, adaptive response, a more specific strategy [1,2].

Adaptative response

Adaptative response, also known as acquired or specific response, allows immune system to recognize specific pathogens and to develop a strategy to neutralize them. Adaptative response is mediated by **B** and **T lymphocytes** that develop different antigen receptors (B cell receptor -BCR- and T cell receptor -TCR-, respectively) located in their membranes that are highly specific and can recognize countless structures. This is possible because, unlike PRRs in innate response, the antigen receptors of adaptative immune response are formed by non-conserved and variable structures that suffer genetic recombination and that leads to the creation of millions of specific antigen receptors. That is the main reason why this third level of immune defence takes longer to achieve a functional and effective mechanism, mainly four or five days after innate response is initiated [1,2].

T lymphocytes

Structure

T-cells are a lymphocytes population with specific antigen receptor called TCR, that is made up by different chains. Actually, there are only two versions of this TCR receptor: **TCR $\alpha\beta$** (more common) and **TCR $\gamma\delta$** (less common), but only one type is expressed in one T-cell. Indeed, TCR is a heterodimer formed by two non-identical polypeptide chains (α , β , γ , and δ) but the only functional combinations possible are $\alpha\beta$ and $\gamma\delta$. Each chain is composed by two domains, **variable domain (V)** and **constant domain (C)**, which have different functions each. Variable domain is essential for the antigen recognition mechanism; by contrast, the main function of the constant domain is being part of the transduction signal pathways that will active different mechanism [5].

In addition, T lymphocytes also have in their cell membrane the **CD3** transmembrane protein that is a co-receptor complex that plays a significant part in the propagation of the signal. This co-receptor complex is made up by **CD3 γ** , **CD3 δ** and **CD3 ϵ** invariable chains, that have similar structures and characteristics, and **CD3 ζ** . This fourth invariable chain (CD3 ζ) is associated to the TCR structure in pairs (dimers) linked to each other through disulphide-links.

These structures, mainly CD3 ζ but also CD3 γ , δ and ϵ , have **immunoreceptor tyrosine-based activation motifs (ITAMs)**: these motifs make the propagation of activation signals possible when they get phosphorylated in the moment the T-cell recognizes it and is activated by the presence of antigen [Fig. 1].

Functions

T lymphocytes have different functions depending on what type of CD are presenting in their membrane cell: **CD4** or **CD8**.

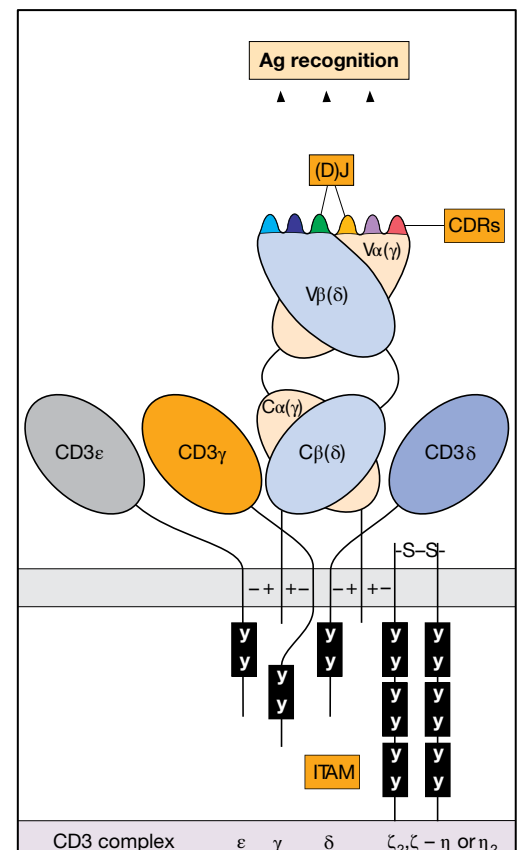

Figure 1. TCR and CD3 co-receptor structure [5].

- The ones presenting **CD4** are called **Th** (T-cell *helper*) because their main purpose and function is to interact with B-cell and other cells (monocytes and macrophages) and to promote activation of macrophages and destruction of pathogens, the activation and differentiation of T-cells and the synthesis of immunoglobulins. These final effects of the Th's actions can be accomplished by the interaction of accessory molecules and by the secretion of cytokines, a broad group of small proteins realized by T-cells to interact and communicate between different cells. Indeed, there are three subsets in T-cell helper population: **Th1**, **Th2** and **Th17** cells. The main difference between them is what molecules and substances they secrete. For example, **Th1** cells secrete **interferon gamma (IFN γ)** to lead directly the activation of cytotoxic T-cells and macrophages in order to neutralize intracellular pathogens, **Th2** cells secrete **IL-4**, **IL-5** and **IL-13** to activate B-cell antibody response against multicellular parasites. Finally, **Th17** cells make neutrophils and B-cells response effective against extracellular bacteria and fungi by secreting **IL-17** [2,5].
- T lymphocytes subtype that express **CD8** in their cytoplasmatic membrane are known as *cytotoxic* T-cells (**Tc** or **CTL**). When a Tc cell is activated, it promotes the proliferation and differentiation of CTLs and the synthesis and secretion of **perforin** and **granzymes**, which are cytotoxic molecules that are able to lysate cells infected by virus or cancerous cells.

Once an antigen is recognized for the first time by **naïve T-cells**, these antigen-specific T lymphocytes undergo clonal expansion and become able to secrete effector cytokines and trigger cytotoxic activity in a phase that is known as **activation phase**. As a consequence of this activation, the antigen is cleared and these effector T-cells are no longer useful so it starts the second phase, the **contraction phase**, where this Ag-specific cells die by apoptosis or by reducing growth factor levels. Meanwhile, a small percentage of this activated T cells are able to avoid this contraction phase and will become the reservoir of **memory T cells**. Therefore, it starts the third phase called **the memory phase** where these survivor T cells will become memory T cells with special characteristics: memory T cells are formed at higher frequencies than naïve T cells and possess rapid clonal proliferation and activation, among other traits [6].

Basically, there are two different subsets of memory T cells, that differ in the expression of certain surface proteins, areas of the organism where it is possible to find them and their function. For instance, long-lived **central memory T cells (T_{CM})** home secondary lymphoid organs and can rapidly proliferate and differentiate into cells with effector functions in response to antigenic stimulation. In contrast, **effector memory T cells (T_{EM})** are found in inflamed peripheral tissues and possess immediate effector functions, so they provide to us a reactive memory, unlike T_{CM} that mediate protective immunity and they have long-term persistence [7].

Activation

First of all, it is important to mention that, in order to recognize and develop an effective response, T-cells can only interact and recognize antigens when they are presented by **MHC molecules** by antigen presenting cells (APCs). Indeed, there are two different types of MHC molecules, **MHC class I** and **class II**: CD4 on Th cells acts as a co-receptor for MHC II and makes the interaction between TCR and antigen-MHC complex

more stable; CD8 on cytotoxic T-cells helps in the same way to the union of TCR and peptide-MHC class I complex [Fig. 2].

Secondly, the interaction between MHC molecules and TCR is not enough for T-cells to develop a proper response because the association's affinity TCR-antigen-MHC is low and insufficient. As a result of these low affinity, it requires the interaction of other molecules that will increase the affinity and will stabilize this association: these molecules are known as **accessory molecules**. Most important examples of this intercellular adhesion molecules are **CD2/LFA-3**, **VLA-4/VCAM-1** and **LFA-1/ICAM-1**.

Finally, when TCR and MHC-peptide complex interact between them and CD4/CD8 and accessory molecules of intercellular adhesion stabilize their interaction, that provides what it is known as **signal 1**. This stimulation of TCR by MHC-peptide complex it is not enough and T-cell must be exposed to an engagement of **CD28** (on the T-cell) and **B7** (also known as CD80/CD86) co-stimulatory molecules that APCs have in their plasmatic membrane (known as **signal 2**) [Fig. 3].

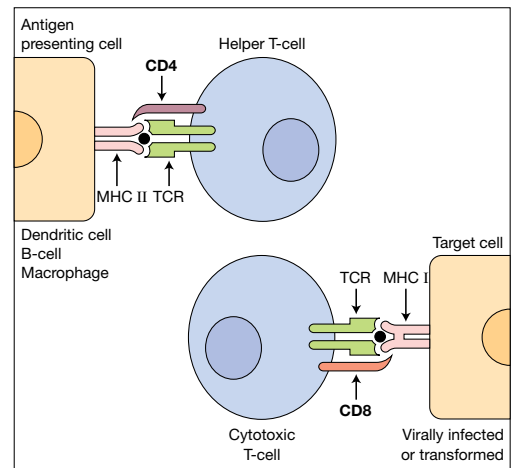

Figure 2. CD8 and CD4's important role in TCR-antigen-MHC complex [5].

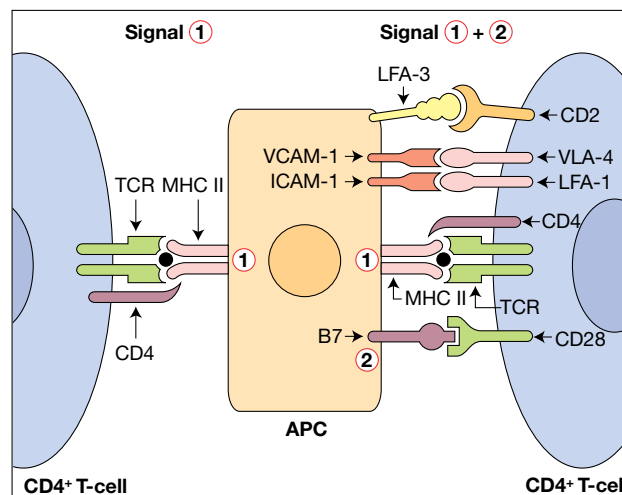

Figure 3. Activation of T lymphocytes [5].

Amplification of the signal: different pathways

Once TCR-MHC-peptide complex is done and stabilized by CD4 or CD8, these co-receptor for MHC intimately associated with **Lck**, a protein tyrosine kinase (PTK), that is able to phosphorylate the three small areas called ITAMs that the two CD3 ζ chains have in their cytoplasmatic tails. As a result of this phosphorylation, it is generated bindings sites for ZAP-70 to come and get activated. Due to this activation, ZAP-70, which actually is a PTK, phosphorylates two adaptor-proteins: **LAT** and **SLP-76**. These activated adaptor-proteins will generate triggered different signalling pathways.

- LAT protein will be used as a platform where another adaptor protein will get linked through these phosphotyrosine residues. For example, **PLC γ 1** and **GRB2**, that will have an important role in **phosphatidylinositol** and **Ras/MAPK**

pathways respectively. In addition, LAT activated protein will make possible the recruitment of **GADS**, an adaptor protein related to SLP-76.

- SLP-76, that is intimately linked to GADS, will generate **cytoskeletal modifications**.

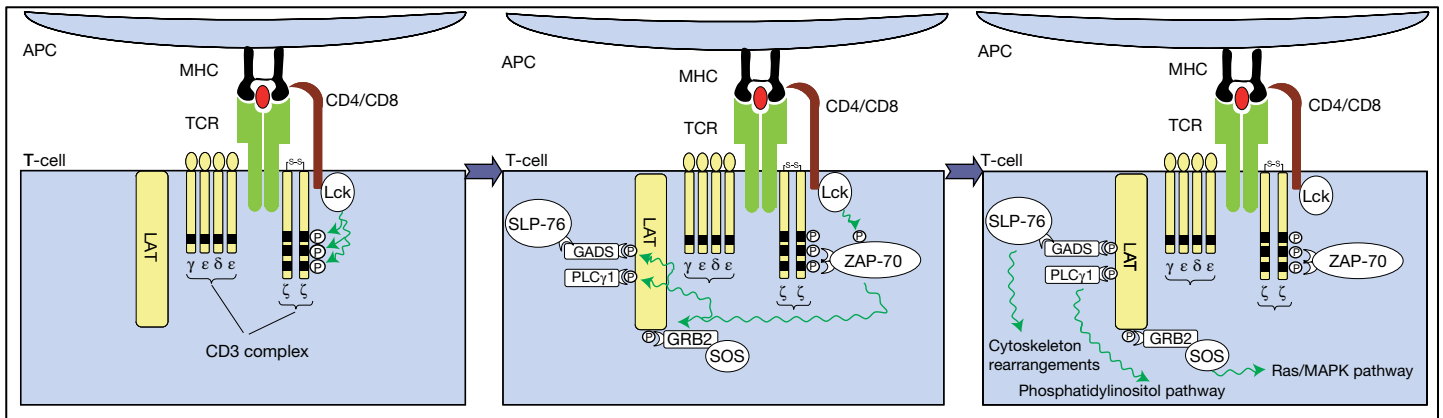

Figure 4. Amplification of the signal leading to different pathways [5]

On one hand, **phosphatidylinositol pathway** will lead to an increase of intracellular Ca^{2+} concentration that will activate **PKC** and **calcineurin** whose function is, among other things, the activation of transcription factors, such as **NFκB** and **NFAT**, that will trigger IL-2 production and other molecules implicated in T-cell activation.

On the other hand, **Ras/MAPK pathway** will lead to the formation of two heterodimers transcription factors known as **Fos/Jun** related to IL-2 production, among another essential transcription factors for T-cell proliferation [5] [Fig. 4].

B lymphocytes

Structure

B-cells are a group of lymphocytes whose receptor is called **BCR**: it has the ability to recognize soluble and particulate antigens through its structure. B-cells receptor complex is made up by a **membrane-bound antibody**, **Ig-α (CD79a)** and **Ig-β (CD79b)**.

The membrane-bound immunoglobulin's structure consists of four polypeptide chains, two heavy chains (**H**) and two light chains (**L**), connected between them by disulphide bridges. Both different types of chains have in their structure one variable region (**V_H** and **V_L**) and one constant region (**C_H** and **C_L**). Indeed, immunoglobulins are formed by three fragments: two **Fab**, that are able to recognize antigens and get united, and **Fc**, which does not have the ability to interact with antigens. There are five types of antibodies or immunoglobulins: IgG, IgM, IgE, IgD and IgA, based on their different structures, functions and origin.

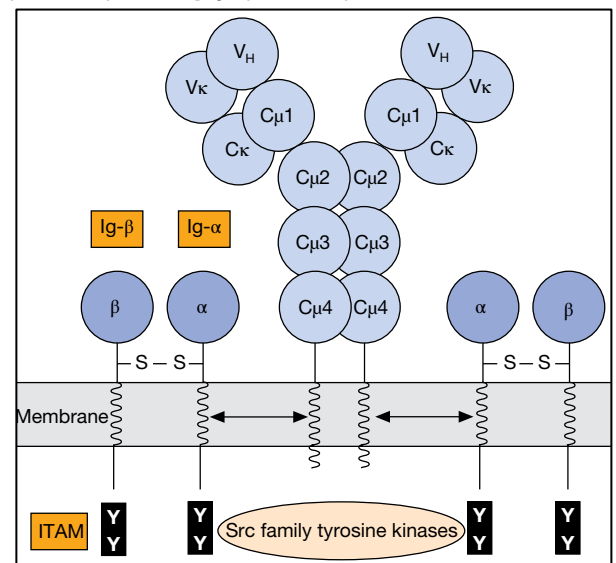

Figure 5. B-cell receptor complex [5].

Transmembrane immunoglobulin's cytoplasmic tail is only a few amino acids long so it is not capable of contain activation motifs to develop a proper response and its propagation. Therefore, an association with transmembrane proteins is necessary since their cytoplasmic structure is long enough to possess ITAMs and transmit signals from the BCR to the cell interior. These transmembrane proteins are **Ig- α** and **Ig- β** , also known as **CD79a** and **CD79b** respectively and they are associated with BCR in two heterodimers (Ig- α /Ig- β), linked between them by disulphide bridges [5] [Fig. 5].

Functions

B-cells provide to the immune system essentials functions: binding to antigen, increase antibody production and execute humoral response. Moreover, they are able to process antigens, fragment them and present this portions to T-cells, in order to achieve B-cell full activation and develop a complex immune response.

There are three fundamental subtypes of B-cells, depending on the area they are found and what type of receptors they express on their surface. **B2 cells**, also known as follicular B-cells because they are found inside lymphoid follicles of the spleen and lymph nodes, are capable of synthesizing highly specific monoreactive BCRs. Usually, they will need the presence of helper T-cells to develop high-affinity antibodies against antigens, which are known as thymus-dependent antigens. **B1 cells** and **marginal zone B-cells (MZ)**, that express low specific polyreactive BCRs in their surfaces that recognize multiple evolutionarily conserved fragments of pathogenic antigens and this recognition is via thymus-independent antigen. As a result, they produce low-affinity antibodies that will be useful to provide rapid response and protection because, unlike the antibodies of B2 cells, they do not require much time to get synthesized because of their low-affinity. These two subtypes in B-cell will be found in different areas of the organism, such as the skin, the mucosa and the marginal zone of the spleen [5].

Basis of B-cell activation

Main tools in B-cells, in order to achieve their activation, may differ depending on how they are being activated: thanks to Th cells antigen presentation or by themselves. Even though this could lead to slight differences, the bases of the mechanisms used are similar and all of them drive these B-cells to their cell cycle and stimulate their activity.

First, B-cells activation starts with the interaction between antigen and the membrane-bound antibody; this connection will lead to the phosphorylation of the tyrosine residues in the ITAMs present in the BCR cytoplasmic tail (Ig- α and Ig- β heterodimer's tails). This first phosphorylation will trigger the B-cell signalling pathway, where many proteins with different roles will provide binding sites, phosphorylation, recruitment and activation of certain kinases and protein complex that will end by class switching, clonal expansion and differentiation of the B-cells.

As T-cells do, B-cells also need two co-stimulation signals to achieve an effective response:

1. First way of co-stimulation in B-cells activation is provided by the **co-receptor complex** when BCR recognizes and interacts tightly with the antigen. Actually, this co-receptor complex is a tetrameric protein complex made up by **LEU13 (CD225)**, **CD81 (TAPA-1)**, **CD19** and **CD21 (CR2)**. CD21, also known as CR2, will be useful in engaging with molecules such as complement (that comes from

innate response). In addition, CD19 is a transmembrane protein exclusive of B-cells that will be hosting several binding sites and phosphorylation items, similar function of LAT complex in T-cell activation. This protein will be crucial in the discussion of this project [Fig. 6].

2. Second co-stimulatory signal comes from the interaction of T and B cells after B-cell activation by transmembrane immunoglobulin-antigen bounding. Indeed, this second form of stimulation takes place by the engagement of **CD40 ligand** (located in T-cell membrane surface) and **CD40** on the B-cell. B-cell recognizes, gets activated and internalizes the antigen while T-cell is being activated and becoming Th thanks to dendritic cells antigen presentation. Once B-cell is presenting the antigen (previously internalized) in their surface (by MHC class II proteins), this T helper cell is able to recognize it, co-stimulate B-cell and, as a result, B-cell will undergo clonal expansion and activation [5] [Fig. 7].

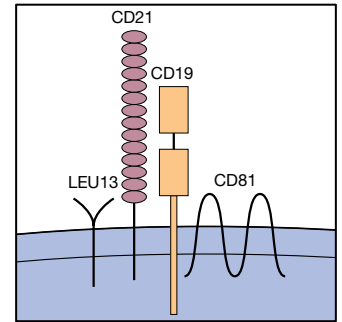

Figure 6. B-cell co-receptor complex [5].

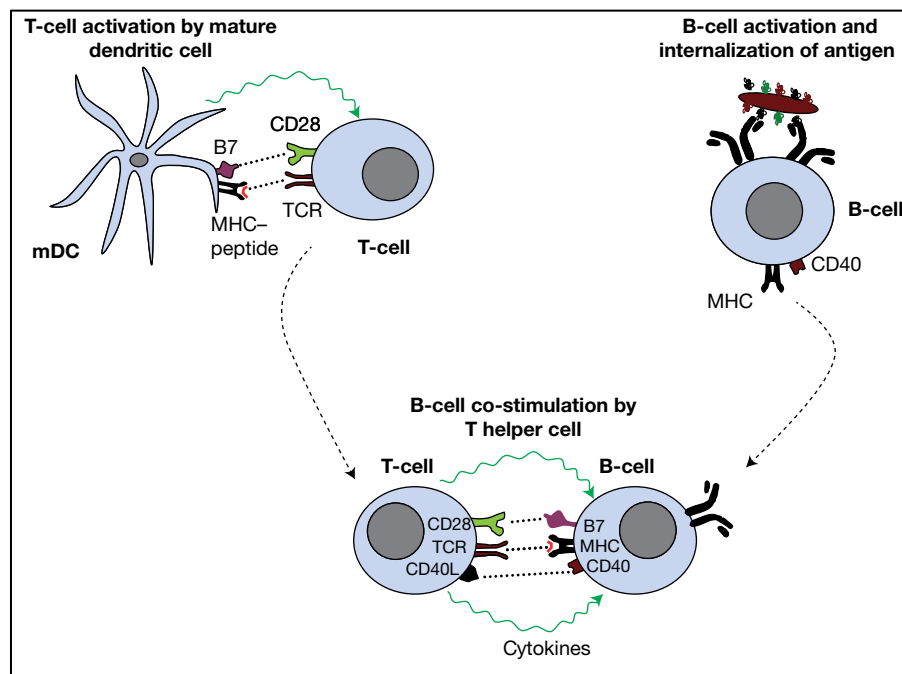

Figure 7. CD40-CD40L dependent B-cell co-stimulation [5].

Immunotherapy and cancer

Immunotherapy, also known as biological therapy, is one of the most recent and revolutionary ways of treating cancer nowadays. The principal aim of immunotherapy is helping the immune system of the patient to increase and improve his immune response against cancer cells. As it has been discussed before, human immune system possesses the necessary tools to kill cancer cells and suppress tumour developing. However, are cancer cells able to survive and become a tumour in spite of being surrounded by immune cells such as T-cells, macrophages and B-cells? This inefficacy and failing of immune system is known as Hellström paradox, but in last decades the answers have been clearing out: cancer cells are able to express and produce inhibitory molecules and proteins to avoid immune system and escape from immune surveillance [8-10].

Nowadays, immunotherapy is in constant developing and investigating new techniques and strategies to treat cancer. Up to date, it is possible to classify them this way:

- Virus therapy: there are certain viruses that have been modified in the laboratory with the purpose of infecting cancer cells and making them express viral antigens in their surface to become more visible for the immune system. Another strategy is modifying viruses so they can provoke the lysis of cancer cells.
- Checkpoint inhibitors: these agents stimulate the immune system by reducing apoptotic lymphocytes death rates.
- Monoclonal antibodies: they are made in the laboratory and modified in order to detect certain parts of cancer cells and kill them.
- Cancer vaccines: introducing inside the organism fragments of cancer cells helps, in some cases, to prevent and even treat cancer.
- Cytokines: substances secreted by immune system that help to stimulate and activate the response against cancer cells.
- Immunomodulators: chemical substances that are able to interact with B-cells, T-cells and other components of immune system and help them to increase their interaction and cooperation, producing a more effective response.
- Chimeric Antigen Receptor (CAR) T-cell therapy: this type of immunotherapy has been developing for the latest years with satisfactory results in different types of blood cancer such as acute lymphoblastic leukaemia (ALL). This novel therapeutic strategy will be discussed on the rest of this final degree project.

OBJECTIVES

The main purpose of this final degree project is to evaluate the current situation of immunotherapy in Spain, focusing on two new antineoplastic agents recently authorized, Yescarta® and Kymriah®.

1. To explain how immunotherapy has evolved into developing CAR-T cells treatment.
2. To show all the steps that follow manufacturing CAR-T cells, from collecting T-cells from the patient to infusing genetically modified T-cells into the patient.
3. To evaluate the two recently approved treatments, Yescarta® and Kymriah®, and study their similarities and differences.
4. To explicate and divulge which are the current trends in CAR-T immunotherapy and in what they might evolve in the following years.

MATERIAL AND METHODS

This final degree project is based on bibliographic research where databases, official websites and some books have been useful to develop this project.

On one hand, databases such as PubMed and Scopus have been used to search information and find scientific articles suitable for the topic of this project. In addition, Google Scholar was also used to do a preliminary research, that helped me to make an idea of the availability of articles of my interest. Although several scientific articles published in various scientific journals were found, in order to guarantee the latest, reliable and relevant information, only those articles and reviews most cited and recently published were firstly considered.

On the other hand, search engine from official organizations websites such as the FDA, the AEMPS, the EMA and ClinicalTrials.gov were also used to find official assessment reports of Kymriah® and Yescarta® and another relevant information.

Finally, consulting scientific books has been very useful in the development of this project, mainly used in the introduction part.

RESULTS

The history of CAR-T cells

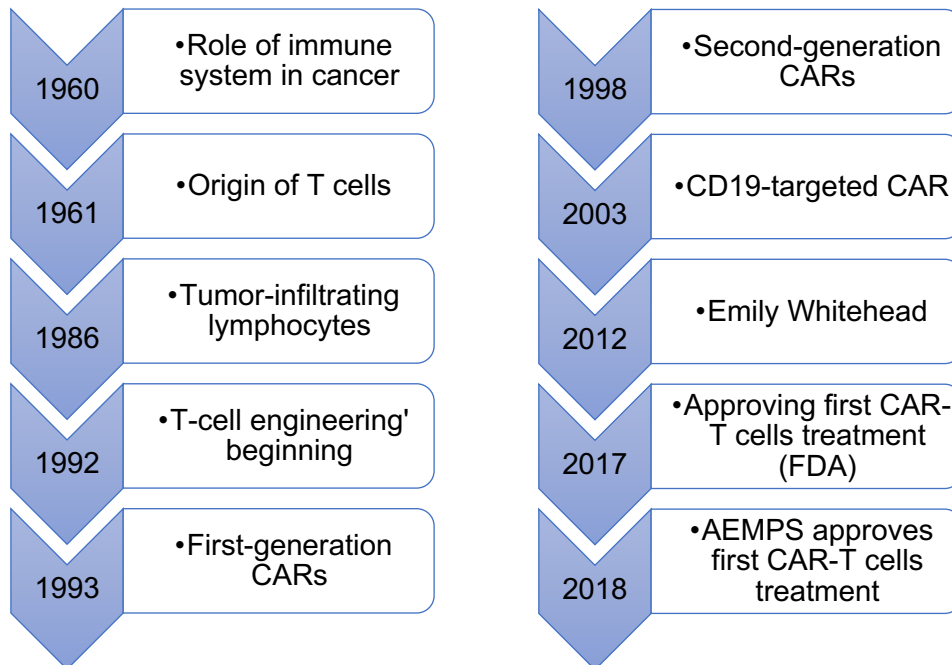

Figure 8. Historical timeline of the development of CAR T cell therapy.

Main discoveries and events that led to the creation of CAR T cell therapy as it is known nowadays are represented schematically on Figure 8; these historical events will be explained in detail in this section.

In 1960, Eva and George Klein, both tumour biology and cancer immunology's specialists, were pioneers in demonstrating the immune system potential to battle cancer cells. Despite of this important role, they did not discover what types of cells were implicated. Next year, Jacques Miller discovered the function of the thymus and helped to identify thymus derived cells (now known as T-cells).

From the 60s to the 80s, the main treatment to battle cancer was chemotherapy, surgical procedure and radiotherapy, but the Surgery Department of National Cancer Institution (USA), led by Steven Rosenberg, achieved the first tumour-infiltrating lymphocytes treatment successfully [11]. This fact demonstrated the great capacity of immune system to treat cancer with your own immune cells.

In the following decade, scientists started focusing on using retroviral vectors [12] to add certain genes into cells to develop new structures or gain different functions: due to that new engineering tool, known as gene-transfer techniques, the basis to develop CAR-T cells in the future were finally settled.

First CAR T-cells were developed by Dr. Zelig Eishhar, from the Weizmann Institute of Science (Israel), in collaboration with Dr. Steven Rosenberg. They were able to develop the first CAR T-cell therapy targeting cancer cells in human melanoma, but the stability

and effectiveness were not enough. In the late 90s it was discovered that a co-stimulatory sign in CAR T-cells could increase the results: the survival, proliferation and persistence were better in that second-generation CAR T-cells. In 2002, that new generation was studied targeting directly prostate-specific membrane antigen (PSMA); in that trial, it was verified the potential of 2nd-generation CAR T-cells to lyse cells that expressed PSMA and the effectiveness of the co-stimulatory molecules [13].

One year later, in 2003, a team of scientists modified T-cells in order to express co-stimulatory signals and targeting CD19 [14], a typical protein in the B-cells membrane. In fact, this CD19 is a biomarker for B-cell development but also for lymphoma diagnosis and treatment [15]; a T-cell targeting CD19 antigen could reduce B-cell population in blood cancer such as ALL and non-Hodgkin lymphoma.

On April 17, 2012, a 7-year-old girl called Emily Whitehead with ALL enrolled a clinical trial after having been treated with several rounds of chemotherapy and not getting a good response. A few months later, Emily was the first paediatric patient to be treated with CAR-T 19 therapy successfully.

Finally, after several years of clinical trials, in 2017 the FDA approved two new CAR-T 19 therapies to treat two different types of blood cancer in paediatric and young adult patients: Kymriah® and Yescarta®. This approval changes the entire pharmacological and medical paradigm, letting a new path in treatment developments.

On September 2018, the AEMPS approved those two new treatments and became the first CAR-T therapies available in Spain to treat different types of blood cancer.

Cancer cell therapy

Adoptive Cell Therapy

Adoptive cell therapy (ACT) is a potential treatment of several types of cancer that the scientific community has been developing since the 80s. As a matter of fact, ACT started settling its basis thanks to Steven Rosenberg's study [11] where lymphocytes were extracted from melanomas, expanded in vitro and re-infiltrated into the patient. Those tumour-infiltrating lymphocytes were able to achieve the lysis of autologous tumour cells and due to that new type of immunotherapy seemed to induce the regression of the tumour and produce higher responses.

Nowadays, ACTs can be classified in three different therapies:

- Tumour-infiltrating lymphocytes (TIL): a methodology based on extracting T lymphocytes from inside of the tumour, activating them and promoting their growth thanks to IL-2. Once this T-cell population have grown enough, this T-cells are re-infused into the patient [16].
- Engineered T cell therapy (TCR therapy): This approach is similar to TIL but, instead of just isolate T-cells and make them grown, it also involves genetical modification in order to express a specific TCR that matches and can recognize a certain cancer antigen. Furthermore, it exists the possibility to add additional genes, such as certain genes to express cytokines or other proteins to promote their survival and proliferation in the body of the patients [17,18].

- Chimeric antigen receptor (CAR) T cell therapy: it is also a strategy that involves the genetic modification of T cells, but it does not aim to express a different TCR on their surface but to express a recombinant receptor made of two different parts: a specific part of an antibody and the internal domain of a TCR [17,18].

CAR T cells

The basic structure of this synthetic receptor consists of three different parts:

- An **extracellular domain**, a **single-chain variable fragment (scFv or Fv)** derived from a murine antibody targeting a specific tumour antigen.
- A **transmembrane domain**, that makes this structure more flexible to adapt the antigen-receptor link and also affects signal transduction.
- An **intracellular domain** that plays an essential role in signal transduction and function, depending on which CAR generation it is being referred, this domain will have different designs [19].

As it is explained before, TCR complex only recognize antigens by MHC-mediated recognition, but the immunoglobulin structure of the CAR's antigen recognition domain does not require MHC-mediated recognition and it provides to CAR therapy the possibility to identify and get linked to a large number of antigens [20]. Even though this immunoglobulin fragment provides high affinity and specificity, also only allows to recognize cell surface antigens.

In order to achieve the best results, there have been five generations of CAR cells in the past decades [Fig. 9]. Extracellular domain's structure remains regular and invariable in the different generations, but the intracellular domain is always restructuring, adapting the intracellular signalling domains to increase the response, avoiding as much as it is possible the adverse effects and achieving good clinical results.

- The **first-generation**, the simplest of all generations, only combines a single-chain variable immunoglobulin domain (scFv) and CD3 complex, the same chain in T cells receptor. Indeed, this CD3 complex is actually CD3 ζ , and the main reason for that is because CD3 ζ has in its structure three ITAM motifs, whose activation is the main responsible factor for the stimulation of the signal propagation. Thus, this CD3 ζ chain and the ITAM motifs' phosphorylation, can provide the T cell activation, IL-2 secretion, and the enhancing of anti-tumour activity and can promote target cells lysis [18].
- Once scientist tested this first generation CAR T-cells, they concluded that the survival, proliferation and anti-tumour activity were limited in vivo, so they started developing a new strategy: adding a co-stimulatory signal to increase the potential of this therapy and improve clinic results. A **second-generation** receptor comprises a domain for binding an antigen (scFv), a CD3 ζ cytoplasmatic domain for T-cell activation and a co-stimulatory component. It exists a vast number of different second-generation designs, depending on what co-stimulatory domain is being used. Most studied second-generation CAR T cells are those whose structure consists of 4-1BB (also known as CD137) or CD28 signalling domains. In fact, the only two CAR-T cells treatment approved are based on these co-stimulatory signals [21].

- So as to further improve, many groups of researchers have designed a **third-generation** CAR T cells: this generation is based on second-generation receptors but the difference is the incorporation of a second costimulatory domain, which helps to drive full T cell activation and proliferation.
- The **fourth-generation** of CAR T cells, also known as T cells redirected for universal cytokine-mediated killing (TRUCKs), are based on the second and third generations but with an additional modification: they are bioengineered with a constitutive or inducible expression of a transgenic protein in order to release and secrete important substances such as cytokines and promote tumour killing thanks to diverse synergistic mechanisms such as exocytosis [22,23].
- A **fifth-generation** of CAR T cells is currently being developed: It is based on second-generation CARs structure but it includes a truncated cytoplasmatic domain from the IL-2 receptor β -chain with a binding site for STAT3 or/and STAT5. Once this T cell is activated by antigen-specific activation, it triggers the activation of CD3 ζ , costimulatory domain and cytokine-receptor domain and, consequently, it leads to the activation of JAK-STAT3 or/and STAT5 signalling pathways. This simultaneous stimulation of those three signals has shown an enhance of proliferation, persistence and anti-tumour effects [24,25].

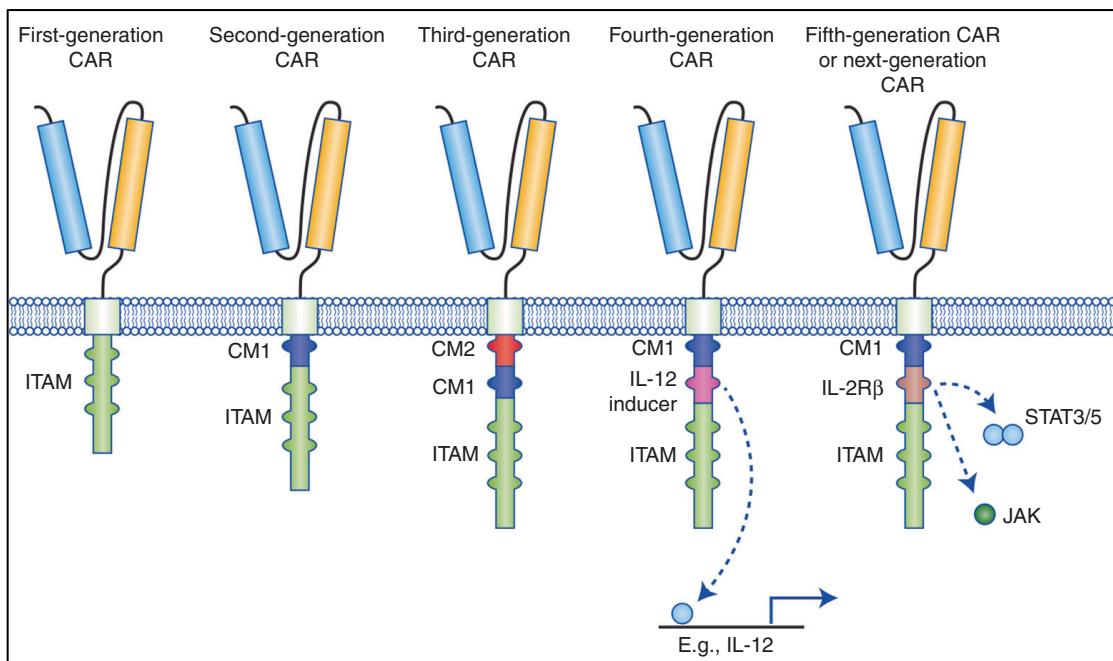

Figure 9. Evolution of CAR T cell development [25].

CD19 CAR Therapy: Kymriah® and Yescarta®

General information

The development and design of clinically functional CAR T cell therapy has evolved into the creation of bio-immune medicines, also known as gene therapy products, that are changing the current cancer treatment situation.

Recently, in September 2018, two brand new antineoplastic agents have been authorized in Spain: **Yescarta®**, whose active substance is **axicabtagene ciloleucel (KTE-C19)**, and **Kymriah®**, latter is **tisagenlecleucel (CTL019)**. These two medicines

are able to treat and cure B-cell acute lymphoblastic leukaemia (ALL) and two different classes of non-Hodgkin lymphomas that are rare cases of hematologic cancer affecting B-cells and that is why they have been designated as an orphan medicines.

As a matter of fact, these two new medicines are synthetic receptors whose extracellular domain, formed by an antibody-derived single chain variable fragment, is targeting a particular protein on tumour cell surface. In fact, they are designed specifically to recognize and get linked to CD19. At the same time, this CD19 protein is used in clinical as a biomarker for B cell malignancies, where the vast majority of B-cell related blood cancer express normal to high levels of this CD19 antigen [15].

The main reason why these two gene therapy medicines have had clinical success lies in their structure and mechanism: axicabtagene ciloleucel and tisagenlecleucel are second-generation CAR T cells that comprise a CD19-specific scFv region and the signalling domains of CD3 ζ and another costimulatory domain, which will be different in both immunotherapy products. For example, the intracellular domain of Kymriah® is made up by CD3 zeta and **4-1BB** as a costimulatory signal domain, while Yescarta® includes CD3 zeta and **CD28** [26,27]. These structural differences in their costimulatory receptor domains will have consequences in their mechanism and transduction signal pathways but, despite of this disparity, it will lead to cytolytic activity and cytokine release, among others functions, in both cases.

CD28 and 4-1BB: different costimulatory domains

CD28 and 4-1BB (or CD137) are intracellular domains often studied and explored as checkpoints in immunotherapy treatments because their activation modules several aspects such as cellular metabolism, survival and persistence [28-30].

In a report carried out by an American scientific team in 2016 [31], they tried to demonstrate how CAR signalling domains could affect and mediate metabolic reprogramming, survival rates cytokines secretion and other important aspects by the activation of different signalling pathways and find an explanation in the observed differences in clinical efficacy for Kymriah® and Yescarta®. They found that 4-1BB CAR T cells can increase central memory T cells' (T_{CM}) population, mitochondrial biogenesis and oxidative metabolism. On the contrary, CD28 plays an important role in increasing effector memory T-cells (T_{EM}) and aerobic glycolysis.

CD28 induces the expression of Glut1, which is an important transporter involved in glucose uptake, and enzymes such as PDK1: both molecules were found in higher proportion in CD28 cells compared to 4-1BB CAR T cells. Another example found was the increase of essential enzymes related to the breakdown of glucose during the glycolytic pathways that achieve higher levels in CD28 cells than in 4-1BB cells. They also found that mitochondrial biogenesis and fatty acid oxidation were significantly higher in 4-1BB CAR T cells than in CD28 cells. All those discoveries suggested that CD28 CAR T cells tend to rely on a glycolytic metabolism, whereas 4-1BB T cells use oxidative breakdown of fatty acids as an energy source.

It is known that, after triggering CAR T cells, it could occur class switching and evolution into memory cell that are critical in the long-term persistence and that it is the key for a good immunotherapy treatment. In fact, this study provides solid evidences which corroborate that CAR T cells with CD28 as a costimulatory domain tend to be less

persistent than the ones using 4-1BB signalling domain because of their metabolic reprogramming: CAR T cells that increase proliferation and persistence enhance oxidative metabolism and that is characteristic of T_{CM}, whereas T cells with aerobic glycolysis is common in T_{EM} and that is the reason why its persistence is less [32,33].

As it can be seen, Figure 10 highlights the main actions caused by this two different costimulatory cytoplasmatic domains in CAR T cells; despite of this slightly differences in the mechanism and process, the final achievement is the activation of T cell response and enhance its proliferation and anti-tumour function.

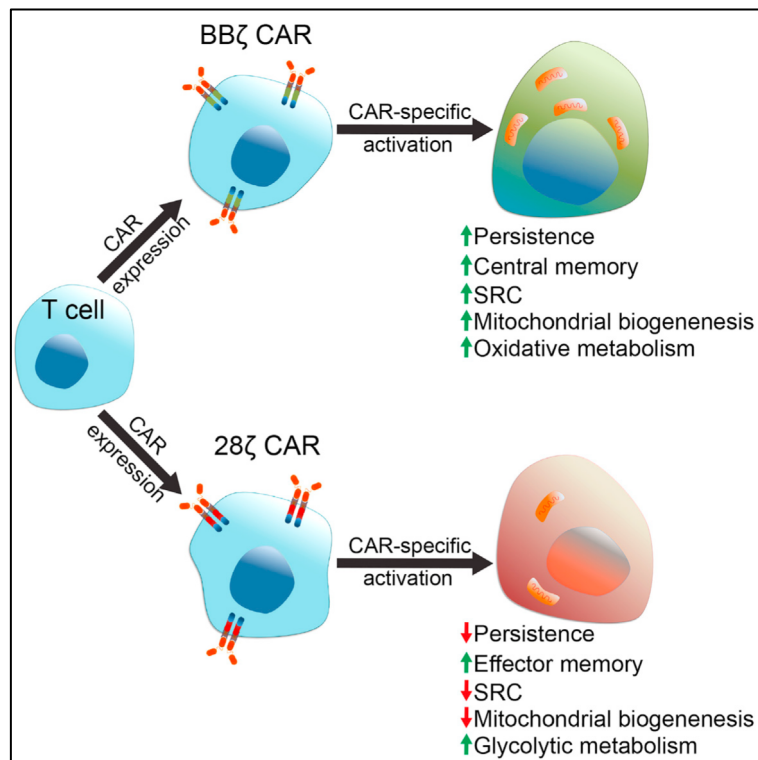

Figure 10. CAR T cells containing 4-1BB or CD28 signalling domains and their respective consequences: BBζ CAR cells are the ones with 4-1BB domain and 28ζ CAR cells possess CD28 as a costimulatory domain [31].

Therapeutic context

Kymriah® and Yescarta® are indicated for the treatment of different types of blood cancer, mainly in paediatric and young adult population, but also in adults; depending on what disease we want to treat and the patient's condition, one or another will be properly indicated. Despite of the different types of B-malignancy, what they have in common is that they are CD19⁺.

In order to have a global view of these gene therapy products, their importance in clinical treatment and understand exactly how they can treat these diseases, it is essential to possess certain knowledge about these blood disorders.

B-cell acute lymphoblastic leukaemia (ALL)

This type of blood cancer is caused by a somatic mutation in one pluripotent hematopoietic stem cell and that mutation triggers clonal proliferation. This gene transformation will have bad consequences on this stem cell differentiation and, thus, the development of mature cells will not occur. ALL is the most common type of blood

cancer in children and adults younger than 20 years (60% of cases) and its most common manifestations are caused by the accumulation of malignant, not differentiated lymphoid cells (lymphoblasts) that can be found mainly in the bone marrow, but also they can be present within different organs such as the spleen, liver and lymphatic nodes, through a process called organ infiltration [34].

Kymriah®, whose active substance is **tisagenlecleucel**, is indicated for the treatment of this haematologic malignancy when the patient is a child or young adult up to 25 years old with B-cell ALL that is refractory (when leukaemia reappears after a period of remission), in relapse (when the disease does not respond to treatment) after a transplant of stem cells or in second or later relapse. This condition is also described as r/r B-cell ALL.

Diffuse large B cell lymphoma (DLBCL)

DLBCL is one of the most common aggressive non-Hodgkin lymphomas (nearly 40% of non-Hodgkin lymphomas in adults). As a lymphoma, lymph nodes, spleen and other organs are affected, unlike leukaemias, which usually are present in circulating blood cells and bone marrow. Commonly, it is caused by the development and growth of a previous lymphoma or its origin may be caused *de novo* as a result of certain gene modifications [35].

Kymriah® and **Yescarta®** are indicated to treat adult patients with refractory or relapse diffuse large B-cell lymphoma, when the patient has been treated with two or more systemic therapies.

Primary mediastinal large B cell lymphoma (PMLBCL)

This third type of haematological cancer is an uncommon disease with a relative frequency around 3% of B-cell non-Hodgkin lymphomas and it is conceived as a subtype of DLBCL, constituting 6% of the cases in this group. Generally, it affects young adults population (between 30-35 years) with a female predominance. It is characterized by a diffuse proliferation of large B-cells within sclerotic tissue and it tends to get compartmentalized, facts that are observed as an invasive mediastinal mass [36].

Yescarta® is the one indicated to treat this disease in adults patients with refractory or relapse PMLBCL that have been treated with two or more lines systemic therapy.

Manufacturing of CAR-T cells

The production of CAR T cells is a complex and difficult process that requires a reproducible T cell manufacturing platform and proper gene-editing and gene-transfer tools in order to achieve the suitable CAR T cells characterization and quality. Several studies and investigations have been necessary to obtain a procedure and a protocol that suit perfectly to the main objective: obtaining the correct number of engineered CAR T cells that will have the desired clinical response once they are re-introduced into the patient [Fig.11].

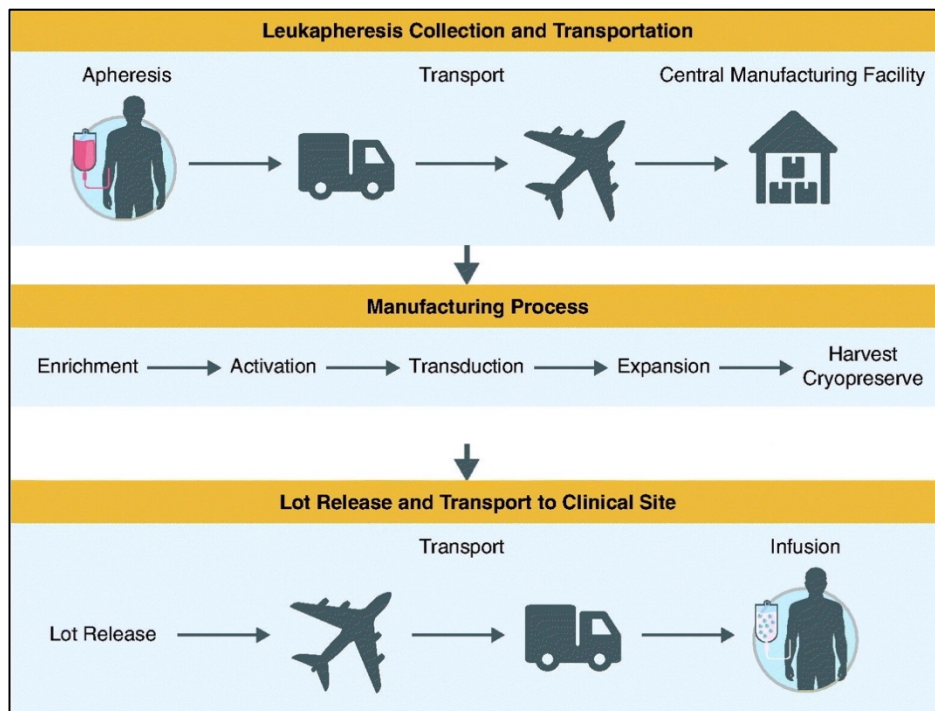

Figure 11. CAR-T cell manufacturing process. Adapted from [26].

Leukapheresis, preservation and transport

As an autologous therapy, the manufacturing process of CAR T cells begins with leukapheresis collection and its transportation. Leukapheresis is a clinical procedure during which blood is withdrawn from the patient's body and peripheral blood mononuclear cells (PBMC), including T-cells, are collected. The remaining blood and its non-necessary components are re-infused into the patient. This isolated PBMC are transported and arrive to the central manufacturing facility where the production of tisagenlecleucel or axicabtagene ciloleucel takes place [17,26].

Before being shipped to the manufacturing facilities, leukapheresis material is cryopreserved within 24 hours after collection and it is stored under -120°C surrounded by a cryomedium environment that guarantees the availability of cells. This cryopreservation allows for early leukapheresis because it is possible to store this frozen material up to 30 months before the manufacturing process begins and the quality of the sample remains stable during this long period [37-38].

Manufacturing process: genetic engineering.

Once the samples of the patient are in the laboratory, T cells in the incoming leukapheresis will be processed slightly different depending on the drug manufacturing protocol, but all these different ways of proceeding share some common steps. Firstly, the patient leukapheresis material is needed to be defrosted under certain conditions and washed to remove the cryogenic solution [38]. Therefore, T cells are enriched and activated before being genetically modified by retroviral vector transduction; during this enrichment and activation, T cells become more receptive to transduction, making easier to modify their genes successfully [39].

The viral vectors used in this type of gene-editing and transduction procedures are gamma-retroviral and lentiviral vectors because, among viral vectors, they have proved being the most efficient and they are able to integrate transgenes that will remain stable

in the host genome and their toxicity is lower than any other viral vector. These gamma-retroviral and lentiviral vectors are derived from retroviruses and lentiviruses respectively, which are subtypes within the *Retroviridae* family. This type of virus possesses the ability to transcribe its RNA genome into cDNA reversely, and that would be the key to the integration of the vector genome into the genome of the T cells. In addition, these viral vectors have lost their capability for self-replicating but not their ability to integrate the synthetic genes located inside them, in this case the CAR gene, into the T cell genetic material. The axicabtagene ciloleucel manufacturing utilizes a gamma-retroviral vector, where transduction occurs at least 48 hours after the activation; tisagenlecleucel manufacturing process is developed by a lentiviral vector, with which it is possible to initiate the transduction phase 24 hour after T cell activation [39,40].

Once T cells have been enriched and activated, this activation leads to the transportation of certain proteins that will be re-ubicated on the plasma membrane surface and the expression of this surface ligands improves success of the transduction process. As a consequence of this process where synthetic DNA (anti-CD19 CAR gene) is inserted into the T cell genome, this cells become chimeric T cells that express a new form of receptor that targets CD19 and whose endodomain is different depending on the targeting immunotherapy, as previously explained. This chimeric gene integration process last 24 hour until is completely done [26]. Following genetic CAR engineering modification, CAR T cells are expanded in a bioreactor in order to achieve the final dose. As it can be seen in Fig. 12, the initial cell population of the patient’s leukapheresis material is evidently different than the final product, which represents a strong evidence of the good manufacturing and quality of the process.

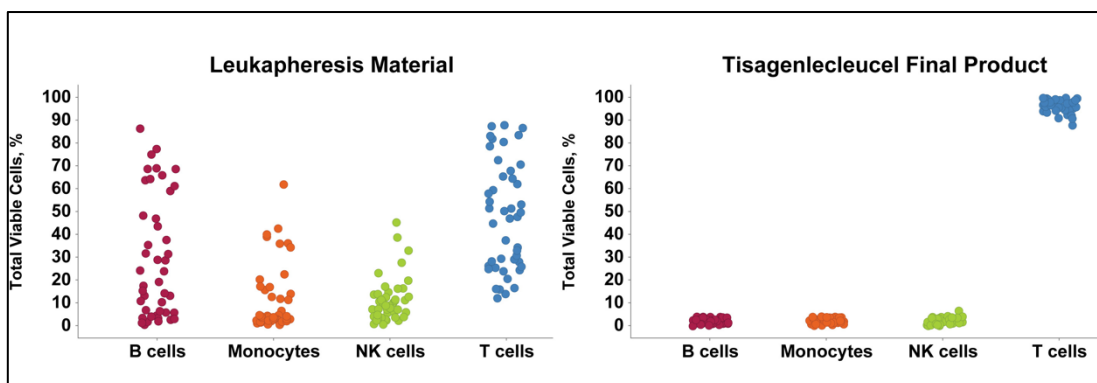

Figure 12 . Cell population differences between initial and final product, focusing in this example on tisagenlecleucel [38].

Even though this graphic represents the difference between initial leukapheresis material and final product composition during ELIANA clinical trial (where tisagenlecleucel was tested), the current final product composition for both immunotherapies is very similar to the image portrayed in the previous figure [38].

After CAR T cell expansion it is required rigorous and robust quality testing so as to verify that this CAR T cell production has been developed following the established and current GMP (Good Manufacturing Practices): the control of final product bags composition, their safety, microbiological presence and others parameters that once were established during their clinical trials and they help to ensure quality, security and effectiveness [41,42].

The final step before leaving the central manufacturing facility is cryopreservation of the final product bags in order to maintain all the quality parameters and ensure that the final

product that will arrive to patients has the same characteristics as when the products bags left the manufacturing laboratories.

During this entire manufacturing process, it is essential to maintain the chain of identity due to Kymriah® and Yescarta® are autologous immunotherapies and these medicines are made from the blood of patients so it must be ensured that patients are treated with their own medicine. To guarantee this traceability and ensure this chain of identity, these companies have developed different protocols and tools, using a unique patient ID, to identify and localise where exactly is the material of patients after leukapheresis, manufacturing and during transport.

Administration into patients: pharmaco-clinical protocol

The administration of this type of immunotherapy treatment requires a certain pharmacological and clinical conditions so as to achieve an early and sustainable response (minimum 18 months) and guarantee the survival of the patients because of the administration of this medicine. General considerations and criteria are slightly different depending on the B-malignancy treated and the CAR T therapy that is being used.

Use of tisagenlecleucel and axicabtagene ciloleucel for DLBCL

- Patient selection criteria: the patients that will be under this treatment must accomplish all of this requirements, that comprise being 18 years old or more, histological diagnosis that certifies the presence of DLBCL and it must be confirmed the presence of refractory or relapse disease, diagnosed by a biopsy. In addition, patients' situation must fit in the Yescarta® and Kymriah®'s indications that have been described previously.
Cardiac, pulmonary, renal and liver functions must be checked to ensure a good management and tolerability of the treatment. Also, it exists certain situations that do not allow this treatment, for instance having uncontrolled autoimmune diseases, patients that are infected with hepatitis B or C and having been treated with another CAR T therapy, among other situations.
- Optimum dose: Both medicines are available in cell suspension for infusion containing a specific concentration of CAR T cells. The dose of axicabtagene ciloleucel is $2 \cdot 10^6$ viable CAR-T cells per kg of body weight with a maximum dose of $2 \cdot 10^8$ viable CAR-T cells for those patients whose body weight is over 100 kg. The dose of tisagenlecleucel is non-weight-based dosing that comprises a suspension ranging $0.6-6 \cdot 10^8$ viable CAR-T cells [43].

Use of tisagenlecleucel for B-ALL

- Patient selection criteria: the treatment for B-ALL using tisagenlecleucel is indicated paediatric patients and young adults up to 25 years old and having a B-ALL refractory or relapse. Other specifications that must be accomplished are: confirming the expression of CD19 in cancerous cells by flow cytometry and the function of the main organs, such as kidney, lungs, liver and heart must be enough so as to tolerate the treatment.
On the other hand and similar to the treatment of DLBCL, there are situations where tisagenlecleucel would not be appropriated and it would not be allowed, such as syndromes where bone marrow is damaged or patients with active virus infection (hepatitis B or C or HIV), among other situations.

- Optimum dose: dosing of tisagenlecleucel is body weight based for patients that weigh 50 kg or less, ranging $0.2-5.0 \cdot 10^6$ CAR-T cells per kg of body weight. Unlike the previous situation, if the patient's weight is over 50 kg, the dose is non-weight-based and it comprises $0.1-2.5 \cdot 10^8$ CAR-T cells [44].

Prior treatment and post-administration monitoring

While tisagenlecleucel or axicabtagene ciloleucel is being developed and manufactured, it is required the patient to undergo a conditioning chemotherapy. Fundamentally, this lymphodepleting chemotherapy uses cytotoxic drugs that plays an important role in enhancing the CAR T cell immunotherapy activity, effectiveness and success rate. During clinical trials many combinations of this cytotoxic drugs have been used, but the ones that have proofed an improvement are the ones that are approved currently: depending on what it is being treated and the immunotherapy used, the lymphodepleting pre-treatment, dosing and duration will be different [26].

The main purpose of the lymphodepleting chemotherapy required before tisagenlecleucel infusion for the treatment of DLBCL is achieving a leucocyte count of 1.000 cells/ μ L or less within a week prior to treatment. If, by any circumstance, tisagenlecleucel infusion delays over 4 weeks and the white cell count of the patient is over 1.000 cells/ μ L, it would be required another lymphodepleting chemotherapy treatment. It is recommended fludarabine (at a dose of 25 mg per square meter of body-surface area) and cyclophosphamide (250 mg/m^2) daily for 3 days. On the contrary, it is recommended fludarabine (at a dose of 30 mg/m^2) and cyclophosphamide (500 mg/m^2) during the fifth, fourth and third day prior axicabtagene ciloleucel infusion for the treatment of DLBCL [43].

For the prior treatment of B-ALL with tisagenlecleucel comprises fludarabine (30 mg/m^2 daily for 4 days) and cyclophosphamide (500 mg/m^2) for two days starting at the same time as fludarabine infusion [44].

The mechanism which fludarabine and cyclophosphamide have a positive impact in the CAR T cell treatment is currently being discussed and explored, but it has been proofed that this lymphodepleting is able to inactivate regulatory T lymphocytes, enhance the presence of APCs and their activation, change the cytokine environment: for instance increasing pro-inflammatory cytokines and T cell activating cytokines such as IL-15. Despite of the fact that this successful mechanism is not entirely comprehended, this prior treatment is essential to achieve an optimal and favourable environment to CAR T cells' survival, expansion, and, consequently, effectiveness [26,45].

Once the plastic bags, that contain the engineered CAR T cells, arrive to the hospital or treatment centre where the treatment will be infuse, the CAR T cells of the patient are thawed and then infused into the patient. This should be done in a hospital setting where the doctors can monitor the patient for side effects and toxicity. Depending on body patient's reaction, it will be necessary to stay in or leave the hospital centre and return a few days after.

Common toxicities of Kymriah® and Yescarta®

As it can be guessed due to their structure, axicabtagene ciloleucel and tisagenlecleucel are anti-CD19 CAR T cells therapies that possess similar mechanism of action so they will share common toxicities. It is important to clarify and understand their mode of action to comprehend their side effects: once these medicines are infused, the expansion of CAR T cells happens during first 1 or 2 weeks after the infusion and after this event follows the optimal long-term persistence. It has been proofed that certain biomarkers such as different cytokines achieve higher levels as a response to expansion, cytotoxicity and persistence [26]. Actually, these engineered-modified T cells are designed to recognize one specific antigen: CD19. Thus, these immunotherapies will have effects on the entire B cell lineage, producing a reduction of population of normal B-cells and neoplastic B-cells indistinctly.

Regarding side effects, the most important toxicities are **cytokine release syndrome (CRS)** and **neurologic events** or **neurotoxicity**. It is believed that these side effects are related to their mechanism of action, despite of the fact that these toxicities are not practically comprehended. Thus, there are not current prevention treatments to avoid these side effects, only palliative measures and immunosuppression are the only available treatments [46].

Cytokine release syndrome

CRS is one of the most common side effects with an incidence greater than fifty per cent of patients. This life-threatening toxicity is caused by the high levels of cytokines released by T cell activation once CAR T cells recognize CD19 antigen in tumour cells and that triggers their activation and expansion. Both activated T cells and immune cells such as monocytes or macrophages secrete a range of cytokines and chemokines that will cause symptomatology such as fever, nausea, fatigue or myalgia. These symptoms could evolve to several hypoxia or vital organs affection that could put in danger patient's life. Indeed, these cytokines and chemokines are used as a biomarker to anticipate the magnitude of the CRS that will appear once the patient is infused: if high levels are found before or one day after infusion, this situation is associated with a future severe CRS [47]. According to [48], there are four different grades of CRS depending on vital signs, different parameters, symptomatology and its severity. For this reason, it is essential monitoring the patient after CAR T cell infusion, for at least seven days, with a total monitoring including vital signs, physical examination and blood count.

The symptomatology during grade 1 is managed with symptomatic treatment only, for instance, if the patient develops fever, will be treated with paracetamol or ibuprofen. In case of the patient's oxygen requirements are less than 40% of fraction of inspired oxygen, it would be an affection within grade 2 that would be treated with intravenous **tocilizumab**. Tocilizumab is a monoclonal antibody anti-IL6-receptor (IL-6R); this election is because IL-6 levels and CAR T cells levels are related to intensity of CRS. Actually, what IL-6 does is interacting with several cell types (not only immune cells), enhancing pro-inflammatory response and, consequently, developing CRS. Even though tocilizumab is only approved for the treatment of rheumatoid arthritis, the off-label use of tocilizumab helps to manage moderate-to-severe CRS episodes. **Corticosteroids** usage is also contemplated when CAR T cells toxicities are still uncontrolled after intravenous tocilizumab. The reason why corticoids are last-line treatment is because,

despite of the fact that they have anti-inflammatory activity, they also are able to reduce T cell function and enhance T cell apoptosis [47].

In addition, some studies have shown that the timing of CRS appearance is related to the CAR structure used: those CAR T cells made up by CD28 as a costimulatory domain (axicabtagene ciloleucel) tend to develop CRS earlier than if it is used CAR T cells with 4-1BB as a costimulatory domain (tisagenlecleucel).

Neurotoxicity

CAR T-cell related encephalopathy syndrome (CRES) is the most common neurological toxicity in CAR T cells infused patients, characterized by handwriting problems, confusion, delirium and disorientation, but could evolve into life-threatening symptoms such as tremors or cerebral oedema that could increase intracranial pressure. It is observed that CRES manifestations has two different phases: the first one occurs during the five days post-infusion, at the same time CRS symptoms; the treatment of this first phase requires **tocilizumab**. The second phase usually is manifested after five days post-infusion, when fever and CRS symptoms cease. Actually, seizures and delirium episodes happen during third or fourth week after CAR T cell infusion and this delayed toxicities within second phase have better response to **corticosteroids**. Even though there are different grades of CRES depending on symptoms, signs and vital parameters and, thus, patient's condition can be treated concretely, CRES status can change rapidly so it is essential having the patient monitored.

Main causes of CRES remain unclear, but several studies pointed out that this neurological side effect could be caused by an increasing of cytokines' presence in the brain (for instance, high levels of IL-6 have been found) but also the presence of T cells into Central Nervous System (CNS) could be responsible for these sever neurologic events.

In addition, some of the symptoms and signs of CRS and CRES could happen simultaneously so it is important a strong medical judgment in order to discern between them and also differentiate between CAR T cell related side effect and other concurrent medical conditions [47].

National approach: situation in Catalonia

Current situation

Axicabtagene ciloleucel (Yescarta®) from Kite Pharma, a Gilead's company, was the first CAR T therapy authorized in Spain on 6th September 2019, although the second CAR T therapy approved and funded by the Ministerio de Sanidad, Consumo y Bienestar Social (MSCBS). On the other hand, tisagenlecleucel (Kymriah®) from Novartis was authorized in Spain on 17th September 2018 by the AEMPS; despite of being the second CAR T cell therapy approved, Kymriah® became the first CAR T therapy funded by the MSCBS.

This means that, despite of being high-cost immunotherapies, patients whose B cell malignancies (B-ALL, DLBCL or PMLBCL) have been treated several times with non-satisfactory results, they have another opportunity to be treated and try to give hope to these cases that didn't have any other treatment.

In Spain there have been designated 11 hospital centres where CAR T cell therapy can be used; depending on which specialised setting they can provide (for instance, paediatric specialist centre or not) certain uses of this CAR T cell therapy will be allowed. In addition, there are three hospital centres with an exceptional use in case of the designated health centres have an amount of activity that exceeds their management.

Particularly in Catalonia, there are four hospital centres where these kind of treatments are being administered: Hospital Clínic, Hospital de la Santa Creu i Sant Pau, Hospital Vall d'Hebron, Hospital Sant Joan de Déu. Each one is specialised in the treatment of patients of different ages and diseases, for instance, and more remarkably, Hospital Sant Joan de Déu was the first hospital centre in treating a B-ALL paediatric patient with CAR-T therapy (Kymriah®), the first treatment promoted by the Sistema Nacional de Salud (SNS) [49]. Indeed, Hospital Sant Joan de Déu was the first Spanish paediatric hospital being accredited to administer and use this individualised therapy; from that day until 2019 this hospital centre has infused 39 paediatric patients with CD19 CAR-T therapy. These facts emphasise how relevant and pioneering is this hospital in leukaemia and oncology treatments [50].

[Banc de Sang i Teixits: cell-processing laboratory.](#)

The manufacturing process of these two individualised immunotherapies is slightly different in Catalonia due to the intervention of **Banc de Sang i Teixits (BST)** in this process. The BST is a public agency of Departament de Salut de la Generalitat de Catalunya that, among other important functions, has an active role in the Kymriah®'s and Yescarta®'s manufacturing process. BST is responsible of the leukapheresis material reception and quality control, cryopreservation and distribution.

Fortunately, I had the opportunity to talk with a laboratory technician that works in the BST, concretely in the Cell Therapy Unit, where it is processed the leukapheresis material after its collection. She explained to me how the material is processed, the requirements demanded and the protocols their team follow in order to achieve an appropriate *modus operandi*.

Actually, the BST important role is obvious since the beginning of the whole manufacturing process: the leukapheresis collection occurs in **leukapheresis collection units** related to BST; for instance, the collection of patients from Vall d'Hebron takes place in BST-Vall d'Hebron unit.

When leukapheresis material of the patient is sent to BST central facilities, it is received in the **cell processing laboratory** where cell counting and quality control are performed: the samples must accomplish what the manufacturing laboratories demand so one of the BST's mission is adjusting these samples into the reference ranges demanded. For instance, BST laboratory technicians adjust total nucleated cell (TNC) count and the CD3⁺ presence in leukapheresis samples before the material is frozen.

As shown in Figure 13, these are the reference values that Novartis requires before the cryopreserved material is sent to the manufacturing facilities. If the samples do not fit manufacturer's requirements, it is necessary to reduce the volume and adjust the values thanks to Sepax Cell Separation System, which is an automated system that processes blood samples and other cellular products and separates cells. In fact, this cell processing system is coordinated by a protocol software called PeriCell. This software is specially designed for plasma reduction of apheresis products in order to achieve a reduced volume of the samples; it is produced two different bags, one containing the cell extraction, which will be highly concentrated, and the other containing plasma residues.

<u>PROTOCOL COMERCIAL KYMRIA</u>
Batch ID: FHADBE1 Volumen procesado: 11955 ml
V inicial: 200 mL [] inicial: 33,55 E6 CN/mL CNT (E9): 6,7 E9 (>2E9) CD3T (E9): 1,74 (>1E9)
<u>LÍMITS DE CRIOPRESERVACIÓ</u>
- Se congela 1 bolsa de 70 mL
CD3T por bolsa: 1,74 E9 [] por bolsa: 0,958 E8 CN/mL (0,5E8 - 2,5E8) CNT por bolsa: 6,7 E9 (3 - 7E9)
Tubos para Novartis D, E, F y G en FVT1 caja CPE2.CART19 posiciones /1 a /4

Figure 13. Screenshot taken from a computer monitor in BST facilities.

While this cell concentration is being performed, cryopreservation solution is prepared, containing 30% of Viaflo Plasmalyte 148 (pH 7,4), 40% of Human Serum Albumin (HSA), 10% of ACD-A (anticoagulant citrate dextrose solution A), which is an anticoagulant solution for apheresis products, and 20% of a cryoprotectant called DMSO (dimethyl sulfoxide).

Once the cell concentrate bag is obtained, this bag and the cryomedium solution are mixed and added by an automatic device called Smart-Max that can prepare cellular products for cryopreservation.

Finally, seven sample tubes (known as sentinel vials) are collected from this final solution: four of this cryovials will be sent next to the cryopreserved leukapheresis material to manufacturing facilities and the other three will be used to measure cellularity of the sample; that helps to confirm that every step of this cellular processing and cryopreservation have been realised successfully.

The final step of this cell-processing procedure is cryopreservation: first, the cryobags and sentinel vials are frozen in a controlled-rate freezer. When the temperature is -80°C or below, subsequent storage takes place in a vapor phase liquid nitrogen tank where temperature required is -120°C or below. After a minimum of 8 hours remaining in this conditions, cryopreserved leukapheresis materials are completely ready for their shipment and delivery to Novartis or Kite manufacturing facilities. The BST also receives the final product coming from manufacturing laboratories and BST delivers the frozen final product to hospital facility where infusion into patient will be performed.

Furthermore, autologous products as tisagenlecleucel and axicabtagene ciloleucel require that cells collected from one patient must be infused into the same patient so preserving chain of identity is essential to track and verify all materials. In order to ensure safety and accurately identify patient material, unique patient identifiers are used at each

step in the process. The identifiers used to ensure traceability are patient name, date of birth and apheresis ID. This apheresis ID comprehends two different codes: **Donation Identification Number (DIN)**, a code assigned by the International Society of Blood Transfusion (ISBT) that helps to identify each collection event (for BST the code starts by E0025, code also known as Facility Identification Number, FIN). On the other hand, there is the **Single European Code (SEC)**, that helps to identify any tissues or cells donation in the European Union. As a curiosity, this code ends by the expiry date. All these codes and patient data must be visible in the label of the cryobags and cryovials.

Step into the future

Developing autologous CAR T-cell therapies, such as Kymriah® and Yescarta®, has become one of the most promising immunotherapies and their success has motivated the exploration of new scientific paths so as to integrate this CAR T cell concept into other applications.

From autologous to allogeneic

Being an autologous therapy implies avoiding allogeneic reaction such as human leucocyte antigen (HLA) disparities between the donor and the recipient, increasing the safety of the treatment and that provides moderate-to-long term persistence. On the other hand, autologous therapy is synonym of individualized treatment that requires a good leukapheresis material from the patient whose quality may be non-optimal due to patient's characteristics and previous treatments, and a unique manufacturing process which lasts three weeks on average, something negative for patients with advanced and severe disease.

In allogeneic CAR T cells, the origin of the donor would be a healthy donor whose immune system cells have not suffered negative consequences of cancer and chemotherapy treatments, so allogeneic CAR T cells' quality would be greater. Even though the risk of suffering graft-versus-host disease (GVHD) in allogeneic treatments is really high, gene-editing techniques are being developed and used so as to inhibit host immune system's reaction.

In addition, it exists the possibility of creating a cell bank depending on the expression of HLA, in order to avoid HLA disparities, and also having different CAR T cells targeting different antigens so it would be possible to embrace different diseases. Similarly to autologous CAR T cell manufacturing process, leukapheresis material from healthy donor would be transported to manufacturing facilities where these T cells would end genetically modified and posteriorly cryopreserved but, unlike autologous CAR T cells, modified T cells could be stored in cell banks until a patient requires them.

This allogeneic CAR T cell concept is becoming an incredible promising idea with multitude of future applications; this potential is currently being explored, as can be seen in all the existing clinical trials with allogeneic CAR T cells targeting different antigens (the vast majority in preclinical phase) [51].

Solid tumours

Applying CAR T cell therapy to treat solid tumours is currently being a massive challenge for scientific community because CAR T cells as are known nowadays have not proofed being useful for solid tumours. Thus, CAR T cell therapy's limitations are being explored

and analysed so as to address new approaches to achieve robust therapeutic benefit in solid tumours. Following information highlights the main challenges and factors to overcome that require to be studied in order to achieve clinical success in treating solid tumours:

Unlike B-cell malignancies that express high levels of specific antigens on their surface such as CD19, solid tumours derived from neural or epithelial tissue express a large number of surface antigen which are also expressed in high levels in normal tissues. Gene-editing modification to recognise several surface antigen are being developed so as to overcome solid tumours' heterogeneity and, this way, reducing on-target off-tumour toxicity could also be resolved. Due to specific location of solid tumours, the CAR T cells' presence is limited so enhancing their migration and a local administration of the therapy may help to overcome this issue. Also, tumour microenvironment may decrease T cell activity so CAR T cells need to inhibit this suppressive environment by secreting cytokines and checkpoint inhibitors.

However, these strategies are currently being developed and ongoing clinical trials could make possible to expand CAR T cells treatments beyond B-cell malignancies and their progress and efficacy might be seen sooner than is expected [52].

DISCUSSION

This revolutionary individualized immunotherapy that targets CD19 antigen on B-cell lineage has helped to treat hopeless cases of leukaemias and B-cell malignancies, restoring hope in those cases where patients had been treated before without reaching a complete success. Progress in scientific, biological and pharmacological fields have culminated into the development of this innovative autologous immunotherapies, CAR T cells, that act as a booster of host's immune system, enhancing its intrinsic anti-tumour activity and achieving short- and long-term effects.

Recently, two different types of CAR T cell therapies have been approved by the FDA and the AEMPS: Kymriah® and Yescarta®, becoming an important paradigm shift due to their special characteristics. Because of their structure, mechanism of action and intrinsic factors of the patient (the vast majority of them still remain unknown), their clinical data and response are different in each patient. Nevertheless, from a general point of view their clinical data is interpreted as positive and successful.

Tisagenlecleucel was tested in a multicentric phase II clinical trial called ELIANA where paediatric and young adult patients were treated for ALL r/r [53]. The overall remission rate was 81% (95% CI) and the complete remission rate was 60% of the patients; the median response duration was not reached. In addition, tisagenlecleucel was tested in a multicentric phase II clinical trial called JULIET where adults with DLBCL r/r were treated, obtaining the following data: the overall remission rate was 52% (95% CI) and the complete remission rate was 40% of the patients and after 14 months since infusion, the median response duration was not reached [54].

On the other hand, a multicentric, phase II clinical trial known as ZUMA-1 was performed in patients with DLBCL r/r to test axicabtagene ciloleucel. The overall response rate was

82% (95% CI), the complete response rate was 54% and the median response duration was 11,1 months [55].

As it can be seen in the data exposed, the median response duration is achieved on axicabtagene ciloleucel clinical trial whereas on JULIET and ELIANA trials is not. This situation could be intimately related to their intracellular structure, where costimulatory domains had an important role in long-term persistence, among other factors.

Even though these immunotherapies have common indications and it might seem possible to compare, limitations, bias and inherent factors of each clinical trial handicap an effective comparison. Anyway, post-authorisation studies are required in order to obtain long-term safety and effectiveness data and being able to provide a clear view of their safety, effectiveness and efficiency.

In conclusion, it must be highlighted that, although CAR T cells therapies have proofed their effectiveness and good clinical results, moderate-to-severe side effects and the manufacturing, logistic and monetary aspects are challenges that must be overcome in the future. For instance, allogeneic CAR T cells, improving CAR T cell designs, reducing side effects and studying new targets are paths that should be explored in the future so as to become what it is expected from this immunotherapies: the perfect weapon against cancer.

CONCLUSIONS

1. Nowadays, axicabtagene ciloleucel and tisagenlecleucel have become one of the most promising immunotherapies in those cases where B-cell malignancies have turned refractory or relapsed and any treatment is no longer available.
2. There are many factors that modify safety and effectiveness, such as CAR T cell design, leukapheresis material, prior treatments and intrinsic factors of the patients such as immune system response.
3. Side effects have been noticed to be frequent: CRS and CRES are present in at least 50% of treated patients. Their cause is still being understood and studied so it is indispensable to find biomarkers that could be used as correlative factors in order to prevent and anticipate these toxicities.
4. New approaches are currently being studied so as to develop their full potential, such as allogeneic CAR T cells, and also apply this CAR T cell concept into new medical areas such as solid tumours, which seems to be really promising.

BIBLIOGRAPHY

1. Rich RR. *Clinical Immunology: Principles and Practice*. 3rd ed. USA: Mosby Elsevier; 2008. 1578 p.
2. Regueiro JR, López C, González S, Martínez E. *Inmunología: biología y patología del sistema inmune*. 3rd ed. Spain: Panamericana; 2004. 219 p.
3. Wertz PW, de Szalay S. Innate Antimicrobial Defense of Skin and Oral Mucosa. *Antibiotics (Basel)*. 2020;9(159):1-7. [cited 10 03 2020]. Available from: <https://www.mdpi.com/2079-6382/9/4/159> doi: 10.3390/antibiotics9040159
4. Thursby E, Juge N. Introduction to the human gut microbiota. *Biochem J*. 2017;474(11):1823-1836. [cited 10 03 2020]. Available from: <https://www.ncbi.nlm.nih.gov/pmc/articles/PMC5433529/> doi: 10.1042/BCJ20160510.
5. Delves PJ, Martin SJ, Burton DR, Roitt IM. *Roitt's essential immunology*. 13rd ed. United Kingdom: Wiley-Blackwell; 2017. 556 p.
6. Tanel A, Fonseca SG, Yassine-Diab B, Bordi R, Zeidan J, Shi Y et al. Cellular and molecular mechanisms of memory T-cell survival. *Expert Rev Vaccines*. 2009;8(3):299-312. [cited 10 03 2020]. Available from: <https://www.ncbi.nlm.nih.gov/pmc/articles/PMC2680212/> doi: 10.1586/14760584.8.3.299
7. Sallusto F, Geginat J, Lanzavecchia A. Central Memory and Effector Memory T Cell Subsets: Function, Generation, and Maintenance. *Annu. Rev. Immunol*. 2004;22:745-763. [cited 10 03 20]. Available from: <https://www.annualreviews.org/doi/abs/10.1146/annurev.immunol.22.012703.104702> doi: 10.1146/annurev.immunol.22.012703.104702
8. Haidong D, Svetomir M. *The Basics of Cancer Immunotherapy*. USA: Springer; 2018. 160 p.
9. Coventry BJ. Therapeutic vaccination immunomodulation: forming the basis of all cancer immunotherapy. *Ther Adv Vaccines Immunother*. 2019;7:2515135519862234. [cited 11 03 2020]. Available from: <https://www.ncbi.nlm.nih.gov/pmc/articles/PMC6676259/> doi: 10.1177/2515135519862234.
10. Wraith DC. The Future of Immunotherapy: A 20-Year Perspective. *Front Immunol*. 2017;8:1668. [cited 11 03 2020]. Available from: <https://www.ncbi.nlm.nih.gov/pmc/articles/PMC5712390/> doi: 10.3389/fimmu.2017.01668.
11. Rosenberg SA, Packard BS, Aebersold PM, Solomon D, Topalian SL, Toy ST et al. Use of tumor-infiltrating lymphocytes and interleukin-2 in the immunotherapy of patients with metastatic melanoma: a preliminary report. *N Engl J Med* 1988;319:1676-80. doi: 10.1056/NEJM198812223192527
12. Coffin JM, Hughes SH, Varmus HE. *Retroviruses*. New York: Cold Spring Harbor Laboratory Press; 1997. 843 p.
13. Brentjens R, Latouche J-B, Santos E, Marti F, Gong MC, Lyddane C, et al. Human T-lymphocyte cytotoxicity and proliferation directed by a single chimeric TCR ζ /CD28 receptor. *Nat Biotechnol*. 2002; 20:70-75. doi: 10.1038/nbt0102-70

14. Brentjens R, Latouche J, Santos E, Marti F, Gong MC, Lyddane C, et al. Eradication of systemic B-cell tumors by genetically targeted human T lymphocytes co-stimulated by CD80 and interleukin-15. *Nat Med*. 2003;9:279-286. doi: 10.1038/nm827
15. Wang K, Wei G, Liu D. CD19: a biomarker for B cell development, lymphoma diagnosis and therapy. *Exp Hematol Oncol*. 2012;1(1):36. [cited 25 03 2020]. Available from: <https://pubmed.ncbi.nlm.nih.gov/23210908/> doi: 10.1186/2162-3619-1-36
16. Baruch EN, Berg AL, Besser MJ, Schachter J, Markel G. Adoptive T cell therapy: An overview of obstacles and opportunities. *Cancer*. 2017;123:2154-2162. [cited 28 03 2020]. Available from: <https://acsjournals.onlinelibrary.wiley.com/doi/full/10.1002/cncr.30491> doi: 10.1002/cncr.30491
17. Zhao L, Cao YJ. Engineered T Cell Therapy for Cancer in the Clinic. *Front Immunol*. 2019;10(2250):1-20. [cited 28 03 2020]. Available from: <https://www.frontiersin.org/articles/10.3389/fimmu.2019.02250/full> doi: 10.3389/fimmu.2019.02250
18. Zhang Q, Ping J, Huang Z, Zhang X, Zhou J, Wang G, et al. CAR-T Cell Therapy in Cancer: Tribulations and Road Ahead. *J Immunol Res*. 2020;2020:11. [cited 28 03 2020]. Available from: <https://www.hindawi.com/journals/jir/2020/1924379/> doi: 10.1155/2020/1924379
19. Firor AE, Jares A, Ma Y. From humble beginnings to success in the clinic: Chimeric antigen receptor-modified T-cells and implications for immunotherapy. *Exp Biol Med*. 2015;240:1087-1098. [cited 2 04 2020]. Available from: <https://www.ncbi.nlm.nih.gov/pmc/articles/PMC4935283/> doi: 10.1177/1535370215584936
20. June CH, Sadelain M. Chimeric Antigen Receptor Therapy. *N Engl J Med*. 2018;379:64-73. doi: 10.1056/NEJMra1706169
21. Sadelain M, Rivière I, Riddell S. Therapeutic T cell engineering. *Nature*. 2017;545:423-431. doi: 10.1038/nature22395
22. Chmielewski M, Abken H. TRUCKs: the fourth generation of CARs. *Expert Opin. Biol. Ther*. 2015;15(8):1145-1154. doi: 10.1517/14712598.2015.1046430
23. Yu S, Yi M, Qin S, Wu K. Next generation chimeric antigen receptor T cells: safety strategies to overcome toxicity. *Mol Cancer*. 2019;18(125):1-13. [cited 10 04 2020]. Available from: <https://molecular-cancer.biomedcentral.com/articles/10.1186/s12943-019-1057-4> doi: 10.1186/s12943-019-1057-4
24. Kagoya Y, Tanaka S, Guo T, Anczurowski M, Wang C-H, Saso K, et al. A novel chimeric antigen receptor containing a JAK-STAT signaling domain mediates superior antitumor effects. *Nat Med*. 2018; 24(3):352-359. doi: 10.1038/nm.4478
25. Tokarew N, Ogonek J, Endres S, von Bergwelt-Baildon M, Kobold S. Teaching an old dog new tricks: next-generation CAR T cells. *Br J Cancer*. 2019;120:26-27. [cited 11 04 2020]. Available from: <https://www.nature.com/articles/s41416-018-0325-1> doi: 10.1038/s41416-018-0325-1
26. Roberts Z J, Better M, Bot A, Roberts M R, Ribas A. Axicabtagene ciloleucel, a first-in-class CAR T cell therapy for aggressive NHL. *Leuk Lymphoma*. 2018;59(8):1785-1796. [cited 16 04 2020]. Available from:

<https://www.tandfonline.com/doi/full/10.1080/10428194.2017.1387905> doi:
10.1080/10428194.2017.1387905

27. Golchin A, Zarnoosheh Farahany T. Biological Products: Cellular Therapy and FDA Approved Products. *Stem Cell Rev Rep*. 2019;15:166-175. doi: 10.1007/s12015-018-9866-1
28. Cheuk A TC, Mufti G J, Guinn B. Role of 4-1BB:4-1BB ligand in cancer immunotherapy. *Cancer Gene Ther*. 2004;11:215-226. doi: 10.1038/sj-cgt.7700670
29. Forero-Martínez Ivan, Azpilikueta A, Bolaños-Mateo E, Nistal-Villan E, Palazon A, Teijeira A et al. T Cell Costimulation with Anti-CD137 Monoclonal Antibodies Is Mediated by K63-Polyubiquitin-Dependent Signals from Endosomes. *J Immunol*. 2013;190(12):6694-6706. [cited 21 04 2020]. Available from: <https://www.jimmunol.org/content/190/12/6694> doi: 10.4049/jimmunol.1203010
30. Nandi D, Pathak S, Verma T, Singh M, Chattopadhyay A, Thakur S et al. T cell costimulation, checkpoint inhibitors and anti-tumor therapy. *J Biosci*. 2020;45(50):1-36. doi: 10.1007/s12038-020-0020-2
31. Kawalekar O, O'Connor R, Fraietta JA, Guo L, McGettigan SE, Posey Jr. AD et al. Distinct Signalling of Coreceptors Regulates Specific Metabolism Pathways and Impacts Memory Development in CAR T Cells. *Immunity*. 2016;44(2):380-390. [cited 21 04 2020]. Available from: [https://www.cell.com/immunity/fulltext/S1074-7613\(16\)30008-5](https://www.cell.com/immunity/fulltext/S1074-7613(16)30008-5) doi: 10.1016/j.immuni.2016.01.021
32. Ying Z, He T, Wang X, Zheng W, Lin N, Tu M et al. Parallel Comparison of 4-1BB or CD28 Co-stimulated CD19-Targeted CAR-T Cells for B Cell Non-Hodgkin's Lymphoma. *Mol Ther Oncolytics*. 2019;15:60-68. [cited 21 04 2020]. Available from: [https://www.cell.com/molecular-therapy-family/oncology/fulltext/S2372-7705\(19\)30073-7?returnURL=https%3A%2F%2Flinkinghub.elsevier.com%2Fretrieve%2Fpii%2FS2372770519300737%3Fshowall%3Dtrue](https://www.cell.com/molecular-therapy-family/oncology/fulltext/S2372-7705(19)30073-7?returnURL=https%3A%2F%2Flinkinghub.elsevier.com%2Fretrieve%2Fpii%2FS2372770519300737%3Fshowall%3Dtrue) doi: 10.1016/j.omto.2019.08.002
33. Abate-Daga D, Davila ML. CAR models: next-generation CAR modifications for enhanced T-cell function. *Mol Ther Oncolytics*. 2016;3(16014):1-7. [cited 21 04 2020]. Available from: [https://www.cell.com/molecular-therapy-family/oncology/fulltext/S2372-7705\(16\)30038-9?returnURL=https%3A%2F%2Flinkinghub.elsevier.com%2Fretrieve%2Fpii%2FS2372770516300389%3Fshowall%3Dtrue](https://www.cell.com/molecular-therapy-family/oncology/fulltext/S2372-7705(16)30038-9?returnURL=https%3A%2F%2Flinkinghub.elsevier.com%2Fretrieve%2Fpii%2FS2372770516300389%3Fshowall%3Dtrue) doi: 10.1038/mto.2016.14
34. Terwilliger T, Abdul-Hay. Acute lymphoblastic leukemia: a comprehensive review and 2017 update. *Blood Cancer J*. 2017;7:1-12. [cited 03 05 2020]. Available from: <https://www.nature.com/articles/bcj201753> doi: 10.1038/bcj.2017.53
35. Hoffbrand A-V. *Essential Haematology*. London: Wiley-Blackwell; 2011. 454 p.
36. Wehde N, Borte G, Liebmann A, Al-Ali HK, Niederwieser DW, Poenisch W. Primary mediastinal large B cell lymphoma: Frontline treatment with an alternating chemotherapy regimen based on high dose methotrexate - A single institution experience. *J Med Soc*. 2017;31:8-13. [cited 03 05 2020]. Available from: <http://www.jmedsoc.org/downloadpdf.asp?issn=0972-4958;year=2017;volume=31;issue=1;spage=8;epage=13;aualast=Wehde;type=2> doi: 10.4103/0972-4958.198427
37. Wang X, Rivière I. Clinical manufacturing of CAR T cells: foundation of a promising therapy. *Mol Ther Oncolytics*. 2016;3(16015):1-7. [cited 07 05 2020]. Available from: <https://www.cell.com/molecular-therapy-family/oncology/fulltext/S2372->

- [7705\(16\)30039-0?_returnURL=https%3A%2F%2Flinkinghub.elsevier.com%2Fretrieve%2Fpii%2FS2372770516300390%3Fshowall%3Dtrue](https://doi.org/10.1038/mto.2016.15) doi: 10.1038/mto.2016.15
38. Tyagarajan S, Spencer T, Smith J. Optimizing CAR-T Cell Manufacturing Processes during Pivotal Clinical Trials. *Mol Ther Methods Clin Dev.* 2019;16:136-144. [cited 07 05 2020]. Available from: https://cell.com/molecular-therapy-family/methods/retrieve/pii/S2329050119301433?_returnURL=https%3A%2F%2Flinkinghub.elsevier.com%2Fretrieve%2Fpii%2FS2329050119301433%3Fshowall%3Dtrue doi: 10.1016/j.omtm.2019.11.018
 39. Swiech K, Ribeiro KC, Picanço-Castro V. Chimeric Antigen Receptor T Cells: development and production. São Paulo: Humana Press; 2020. 274 p.
 40. Kurian KM, Watson CJ, Wyllie AH. Retroviral vectors. *Mol Pathol.* 2000;53(4):173-176. [cited 07 05 2020]. Available from: <https://www.ncbi.nlm.nih.gov/pmc/articles/PMC1186965/> doi: 10.1136/mp.53.4.173
 41. European Medicines Agency. Committee for Medicinal Products for Human Use. Assessment report: Kymriah. EMA/485563/2018 [Internet]. Netherlands; 2018. [cited 09 05 2020]. Available from: https://www.ema.europa.eu/en/documents/assessment-report/kymriah-epar-public-assessment-report_en.pdf
 42. European Medicines Agency. Committee for Medicinal Products for Human Use. Assessment report: Yescarta. EMA/481168/2018 [Internet]. Netherlands; 2018. [cited 09 05 2020]. Available from: https://www.ema.europa.eu/en/documents/assessment-report/yescarta-epar-public-assessment-report_en.pdf
 43. Dirección General de Cartera Básica de Servicios del SNS y Farmacia. Protocolo farmacoclínico del uso de tisagenlecleucel y axicabtagen ciloleucel en linfoma B difuso de células grandes en el Sistema Nacional de Salud [Internet]. Madrid; 2019. [cited 09 05 2020]. Available from: https://www.mscbs.gob.es/profesionales/farmacia/pdf/20191128_Protocolo_farmacoclinico_tisagenlecleucel_axixel_LBDCG.pdf
 44. Dirección General de Cartera Básica de Servicios del SNS y Farmacia. Protocolo farmacoclínico del uso de tisagenlecleucel en la leucemia linfoblástica aguda de células B en el Sistema Nacional de Salud [Internet]. Madrid; 2019. [cited 09 05 2020]. Available from: https://www.mscbs.gob.es/profesionales/farmacia/pdf/20190508_Protocolo_farmacoclinico_tisagenlecleucel_LLA.pdf
 45. Klebanoff CA, Khong HT, Antony PA, Palmer DC, Restifo NP. Sinks, suppressors and antigen presenters: how lymphodepletion enhances T cell-mediated tumor immunotherapy. *Trends Immunol.* 2005;26(2):111-117. [cited 09 05 2020]. Available from: <https://www.ncbi.nlm.nih.gov/pmc/articles/PMC1388277/> doi: 10.1016/j.it.2004.12.003
 46. Zheng PP, Kros JM, Li J. Approved CAR T cell therapies: ice bucket challenges on glaring safety risks and long-term impacts. *Drug Discov. Today.* 2018;23(6):1175-1182. [cited 16 05 2020]. Available from: <https://www.sciencedirect.com/science/article/pii/S135964461730569X?via%3Dihub> doi: 10.1016/j.drudis.2018.02.012
 47. Neelapu SS, Tummala S, Kebriaei P, Wierda W, Gutierrez C, Locke FL et al. Chimeric antigen receptor T-cell therapy – assessment and management of toxicities. *Nat Rev Clin Oncol.* 2018;15:47-62. doi: 10.1038/nrclinonc.2017.148

48. Lee DW, Kochenderfer JN, Stetler-Stevenson M, Cui YK, Delbrook C, Feldman SA et al. T cells expressing CD19 chimeric antigen receptors for acute lymphoblastic leukaemia in children and young adults: a phase 1 dose-escalation trial. *Lancet*. 2015;385(9967):517-528. [cited 16 05 2020]. Available from: <https://www.ncbi.nlm.nih.gov/pmc/articles/PMC7065359/> doi: 10.1016/S0140-6736(14)61403-3
49. Hospital Sant Joan de Déu. Nota de prensa primer paciente pediátrico tratado con CAR-T de la Sanidad Pública. Barcelona; 2019. [cited 13 05 2020]. Available from: https://www.sjdhospitalbarcelona.org/sites/default/files/u1/Sala_prensa/Noticias/2019/nota_prensa_inmunoterapia_cart_castellano.pdf
50. Hospital Sant Joan de Déu. CAR-T 19 Immunotherapy [Internet]. Barcelona. [cited 13 05 2020]. Available from: <https://www.sjdhospitalbarcelona.org/en/oncology/cart-19-immunotherapy>
51. Depil S, Duchateau P, Grupp SA, Mufti G, Poirot L. 'Off-the-shelf' allogeneic CAR T cells: development and challenges. *Nat Rev Drug Discov*. 2020;19:185-199. doi: 10.1038/s41573-019-0051-2
52. Ramakrishna S, Barsan V, Mackall C. Prospects and challenges for use of CAR T cell therapies in solid tumors. *Expert Opin Biol Ther*. 2020;20(5):503-516. doi: 10.1080/14712598.2020.1738378
53. Maude SL, Laetsch TW, Buechner J, Rives S, Boyer M, Bittencourt H, et al. Tisagenlecleucel in Children and Young Adults with B-Cell Lymphoblastic Leukemia. *N Engl J Med*. 2018;378(5):439-448. [cited 21 05 2020]. Available from: <https://www.nejm.org/doi/full/10.1056/NEJMoa1709866> doi: 10.1056/NEJMoa1709866
54. Schuster SJ, Bishop MR, Tam CS, Waller EK, Borchmann P, McGuirk JP, et al. Tisagenlecleucel in Adult Relapsed or Refractory Diffuse Large B-cell Lymphoma. *N Engl J Med*. 2019;380:45-56. [cited 21 05 2020]. Available from: <https://www.nejm.org/doi/full/10.1056/NEJMoa1804980> doi: 10.1056/NEJMoa1804980
55. Neelapu SS, Locke FL, Bartlett NL, Lekakis LJ, Miklos DB, Jacobson CA, et al. Axicabtagene Ciloleucel CAR T-Cell Therapy in Refractory Large B-Cell Lymphoma. *N Engl J Med*. 2017;377(26):2531-2544. [cited 21 05 2020]. Available from: <https://www.nejm.org/doi/full/10.1056/NEJMoa1707447> doi: 10.1050/NEJMoal1707447